

XEBEC S1410

5.25 Inch Winchester Disk Controller

Owner's Manual

Document # 104524
REVISION C-1
AUGUST 1983

© XEBEC SYSTEMS, INCORPORATED 1982

CONTENTS

INTRODUCTION

	Page
1.1 GENERAL	1
1.2 DESCRIPTION	1
1.3 FUNCTIONAL ORGANIZATION	1
1.3.1 Host Interface	1
1.3.2 Processor	1
1.3.3 State Machine	1
1.3.4 SERDES	2
1.3.5 Data Separator	2
1.3.6 Sector Buffer	2

SPECIFICATIONS

2.1 GENERAL	5
2.2 ELECTRICAL	5
2.3 PHYSICAL SPECIFICATIONS	5
2.4 ENVIRONMENTAL REQUIREMENTS	5
2.5 CONNECTORS	5
2.6 CONNECTOR PIN ASSIGNMENTS	7

BOARD SETUP

3.1 GENERAL	9
3.2 BOARD SETUP	9
3.3 MOUNTING CONTROLLER	9
3.4 CONNECTING CABLES	9
3.5 MULTIPLE CONTROLLERS	9
3.6 ADDRESS JUMPER GROUP	12

THEORY OF OPERATION

4.1 GENERAL	13
4.1.1 Conventions	13
4.1.2 Name and Abbreviations	13
4.1.3 Signal Definitions	13
4.2 BASIC OPERATING CONFIGURATION	15
4.3 DETAILED DESCRIPTION	15
4.3.1 Controller Selection	15
4.3.2 Command Mode	16
4.3.3 Data Transfer	17
4.3.4 Status Bytes	17
4.4 PROGRAMMING INFORMATION	18
4.5 COMMANDS	18
4.5.1 Control Byte	19
4.5.2 Logical Address (High, Middle, and Low)	20
4.5.3 Test Drive Ready (Class 0, Opcode 00)	20
4.5.4 Recalibrate (Class 0, Opcode 01)	20
4.5.5 Reserved (Class 0, Opcode 02)	21
4.5.6 Request Sense Status (Class 0, Opcode 03)	21
4.5.7 Format Drive (Class 0, Opcode 04)	23
4.5.8 Check Track Format (Class 0, Opcode 05)	24
4.5.9 Format Track (Class 0, Opcode 06)	24
4.5.10 Format Bad Track (Class 0, Opcode 07)	25
4.5.11 Read (Class 0, Opcode 08)	25

	Page
4.5.12	Reserved (Class 0, Opcode 09) 26
4.5.13	Write (Class 0, Opcode 0A) 26
4.5.14	Seek (Class 0, Opcode 0B) 26
4.5.15	Initialize Drive Characteristics (Class 0, Opcode 0C) 27
4.5.16	Read ECC Burst Error Length (Class 0, Opcode 0D) 28
4.5.17	RAM Diagnostic (Class 7, Opcode 00) 28
4.5.18	Reserved (Class 7, Opcode 01) 28
4.5.19	Reserved (Class 7, Opcode 02) 28
4.5.20	Drive Diagnostic (Class 7, Opcode 03) 29
4.5.21	Controller Internal Diagnostics (Class 7, Opcode 04) 29
4.5.22	Read Long (Class 7, Opcode 05) 29
4.5.23	Write Long (Class 7, Opcode 06) 30
4.6	SECTOR FORMAT 30
4.7	EXECUTION OF DIAGNOSTICS 31
4.8	ERROR CORRECTION PHILOSOPHY 31
4.9	ALTERNATE TRACK ASSIGNMENT AND HANDLING 32
4.10	SECTOR INTERLEAVING 33
	APPENDIX A CONFIGURATION PARAMETERS FOR VARIOUS DISK DRIVES A-1
	APPENDIX B SAMPLE HARDWARE INTERFACE AND PROGRAMMING EXAMPLES FOR A Z-80 BASED MICROPROCESSOR TO INTERFACE TO THE XEBEC S1410 CONTROLLER B-1

LIST OF FIGURES

Figure	Description	Page
1-1	Picture of S1410 Disk Controller	2
1-2	S1410 controller functional organization	3
2-1	Controller board dimensions	6
3-1	Cable, connector and jumper locations	10
3-2	Operating setups	11
3-3	Normal (factory-installed) address jumper	12
3-4	Changed address jumper (controller 1)	12
4-1	Basic operating configuration	16
4-2	Controller select timing	16
4-3	Data transfer to host timing	17
4-4	Data transfer from host timing	18
4-5	Device control block (DCB), format	18
4-5a	Completion status bytes	19
4-6	Sector format	31
4-10	Track format example of 32 sectors-per-track with an interleave factor of 5	33

LIST OF TABLES

Table	Description	Page
2-1	Controller electrical requirements	5
2-2	Controller board specifications (physical)	5
2-3	Controller environmental limits	5
2-4	Controller mating connectors	7
2-5	Connector J1, control signals, pin assignments	7
2-6	Connectors J2 and J3, data signals, pin assignments	7
2-7	Connector P2, host interface, pin assignments	8
2-8	Connector P1, power supply, pin assignments	8
3-1	Jumper locations (W1, W2 and W3)	9
4-1	Host bus status signals	13
4-2	Summary of host bus status signals	14
4-3	Controller-host handshaking	14
4-4	Host bus control signals	14
4-5	Host bus data signals	15
4-6	Type 0 error codes, disk drive	22
4-7	Type 1 error codes, controller	22
4-8	Types 2 and 3 error codes, command and miscellaneous	23
4-9	Sector field description	30

COMMAND CODE SUMMARY

Command Code (hex)	Meaning	Page
00	Test for drive ready	20
01	Recalibrate (position heads on track 00)	20
02	Reserved (not used)	21
03	Request sense status	21
04	Format disk drive	23
05	Check track format	24
06	Format track	24
07	Format bad track	25
08	Read	25
09	Reserved (not used)	26
0A	Write	26
0B	Seek	26
0C	Initialize drive characteristics	27
0D	Read ECC burst error length	28
E0	Ram diagnostic (sector buffer test)	28
E1-E2	Reserved (not used)	28
E3	Drive diagnostic	29
E4	Controller internal diagnostics	29
E5	Read long	29
E6	Write long	30

CHAPTER 1

INTRODUCTION

1.1 GENERAL

The Xebec S1410 Disk Controller can control the operation of up to two 5 1/4-inch Winchester disk drives that have interfaces that are compatible with the interface of the ST-506 disk drive made by Seagate Technology. This means that the S1410 Controller can operate with a large and growing class of 5 1/4-inch Winchester disk drives.

1.2 DESCRIPTION

The S1410 Controller, shown in Figure 1-1, is packaged on a compact printed circuit board whose dimensions are 5-3/4 by 8 inches. The board with this popular form factor mounts easily on many 5 1/4-inch drives. If not mounted directly on the drive, the controller takes up very little space in a typical drive enclosure. Because the controller uses the Shugart Associates System Interface (SASI), it does not require special or complex design considerations in order to communicate with popular host buses. The following list highlights the operating and design features of the controller.

- Interlocked data transfer through the Shugart Associates System Interface (SASI).
- Microprocessor-based architecture (patent pending).
- Full-sector buffer. (256 or 512 bytes).
- Hardware 32-bit ECC polynomial with 11-bit burst correction.
- Field-proven data separator.
- Seagate Technology disk interface.
- Automatic retries during disk access.
- Internal Diagnostics.
- Automatic burst error detection and correction.
- Separate sector format for ID and data fields with individual ECC fields for both the ID and data fields.
- High level command set.
- Variable Interleave.

1.3 FUNCTIONAL ORGANIZATION

The simplified block diagram in Figure 1-2 shows the functional organization of the Controller. Only the major areas are shown.

1.3.1 Host Interface

The host interface connects the internal data bus to the host adapter; the state machine controls the movement of data and commands through the host interface.

1.3.2 Processor

The eight-bit processor is the intelligence of the controller; it monitors and controls the operation of the controller.

1.3.3 State Machine

The state machine controls and synchronizes the operation of the host adapter, SERDES, and sector buffer.

1.3.4 SERDES

The serializer/deserializer (SERDES) converts parallel data from the internal data bus to serial data for transfer to a selected disk drive. It converts serial data from the selected disk drive to parallel data which it places on the internal data bus.

1.3.5 Data Separator

The data separator converts serial NRZ data to MFM for transfer to the selected disk drive. It converts MFM data coming from the selected disk drive to serial NRZ data for the SERDES.

1.3.6 Sector Buffer

The sector buffer stages data transfers between the disk and the host to prevent data overruns.

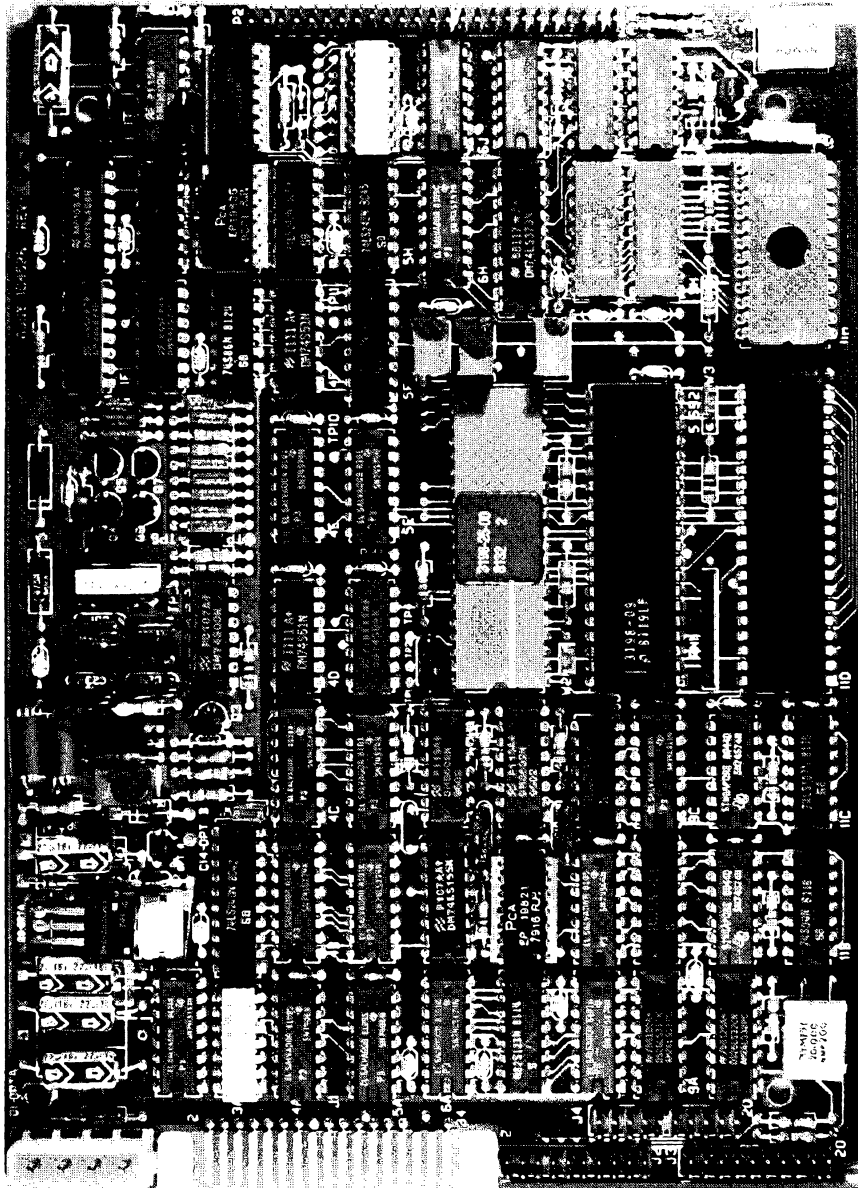

FIGURE 1-1 S1410 DISK CONTROLLER

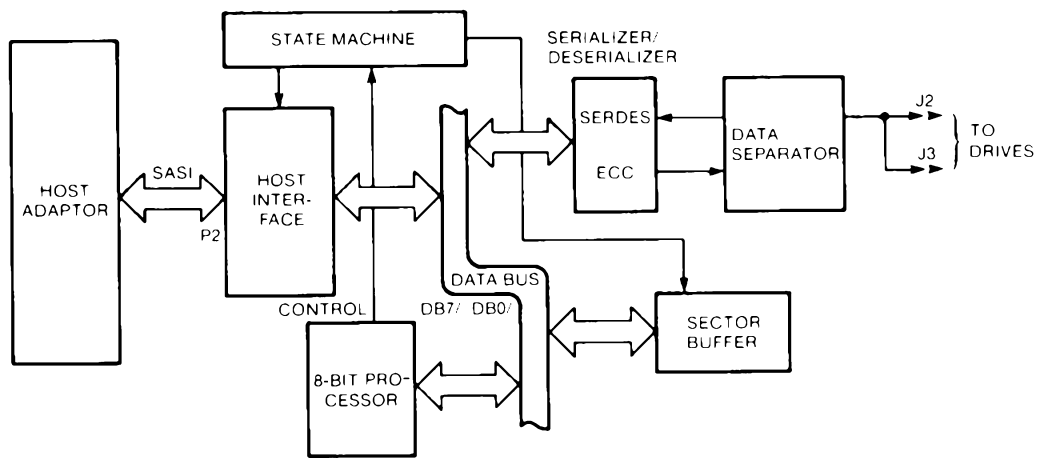

FIGURE 1-2 S1410 CONTROLLER, FUNCTIONAL ORGANIZATION

CHAPTER 2 SPECIFICATIONS

2.1 GENERAL

This chapter contains the overall specifications for the Controller. These specifications are meant to guide the user in placing the controller into operation. Some of the specifications indicate limits; the user must adhere to these in order to operate the controller successfully.

2.2 ELECTRICAL

Table 2-1 lists the electrical requirements of the controller.

TABLE 2-1 CONTROLLER ELECTRICAL REQUIREMENTS

NOTE: All measurements are made on the controller printed circuit board at the power connector P1.

<u>Voltage</u>	<u>Range</u>	<u>Current</u>
+5.0 Vdc	4.75 to 5.25 Vdc	2.5 Amp. Max. 2.0 Amp. Typ.
+12.0 Vdc	10.8 to 13.2 Vdc	66.0 ma. Max. 48.0 ma. Typ.

NOTE: The maximum conducted power supply ripple must not exceed 0.10 volts rms, from 0.1 to 25 MHz.

2.3 PHYSICAL SPECIFICATIONS

Table 2-2 lists the specifications of the controller board and Figure 2-1 illustrates the dimensions of the board.

TABLE 2-2 CONTROLLER BOARD SPECIFICATIONS

<u>Item</u>	<u>Measurement</u>
Width(W)	5.75 inches
Length (L)	8.00 inches
Height (H) (Board thickness, components and lead protrusion)	0.75 inches
Weight	9.0 ounces

2.4 ENVIRONMENTAL REQUIREMENTS

The controller will operate under the environmental conditions listed in Table 2-3. The controller does not normally require fans in standard operating environments where airflow is not restricted.

TABLE 2-3 ENVIRONMENTAL LIMITS

<u>Item</u>	<u>Measurement</u>
Temperature	0 to 55 degrees Celsius
Relative Humidity	10 to 95 percent non-condensing
Altitude	Sea level to 10,000 feet

2.5 CONNECTORS

Table 2-4 lists the Controller mating connectors.

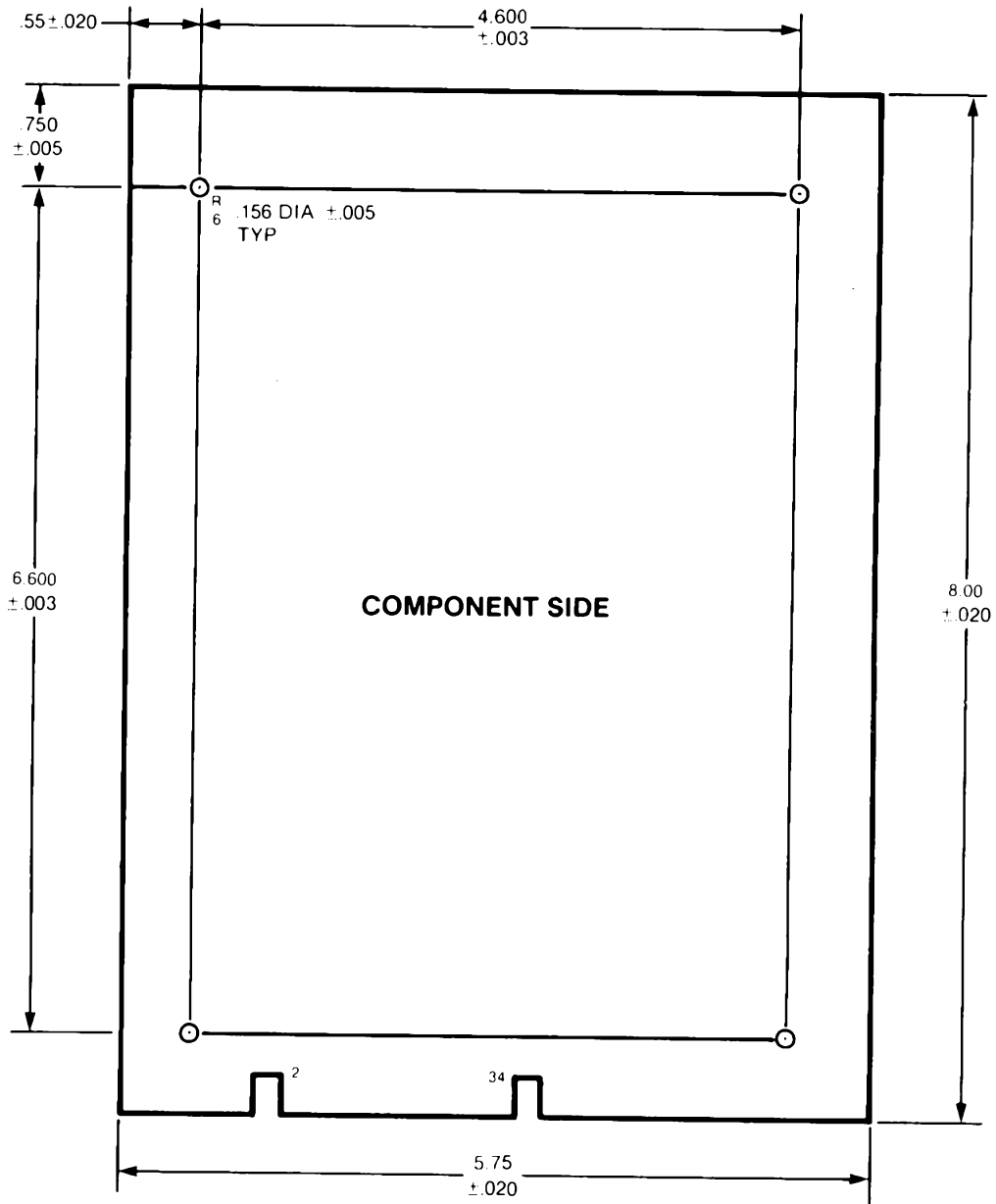

FIGURE 2-1 CONTROLLER BOARD DIMENSIONS

TABLE 2-4 CONTROLLER MATING CONNECTORS

<u>Designation</u>	<u>Function</u>	<u>Type/Source (or equivalent)</u>
J1	Drive control signals	AMP 88373-3
J2,J3	Drive data signals	AMP 86904-1
J4	Test connector	Not applicable
NOTE: The user <u>must not</u> connect a cable to connector J4.		
P1	Power Supply	AMP 1-480424-0(housing) AMP 350078-4(pins)
P2	Host interface signals	AMP 86916-1

2.6 CONNECTOR PIN ASSIGNMENTS

Tables 2-5 through 2-8 list the pin assignments of the connectors on the controller board. The tables identify the signals on the pins. The connector P2 signals are defined in Chapter 4, Theory of Operation.

**TABLE 2-5
CONNECTOR J1, CONTROL SIGNALS, PIN ASSIGNMENTS**

<u>Signal Pin</u>	<u>Ground Return</u>	<u>Signal Name</u>
2	1	Reduced Write Current
4	3	Head Select 2 ²
6	5	Write Select Gate
8	7	Seek Complete
10	9	Track 00
12	11	Write Fault
14	13	Head Select 2 ⁰
16	15	Reserved
18	17	Head Select 2 ¹
20	19	Index
22	21	Ready
24	23	Step
26	25	Drive Select 1
28	27	Drive Select 2
30	29	Reserved
32	31	Reserved
34	33	Direction In

**TABLE 2-6
CONNECTORS J2 and J3, DATA SIGNALS, PIN ASSIGNMENTS**

<u>Signal Pin</u>	<u>Ground Return</u>	<u>Signal Name</u>
1	2	Drive Selected
5	6	Spare
7	8	Reserved
—	—	Spares, pins 9 and 10
11	12	Ground (GND)
13		MFM Write Data+
14		MFM Write Data-
15	16	Ground (GND)
17		MFM Read Data+
18		MFM Read Data-
19	20	Ground (GND)

**TABLE 2-7
CONNECTOR P2, HOST INTERFACE, PIN ASSIGNMENTS**

<u>Signal Pin</u>	<u>Ground Return</u>	<u>Signal Name</u>
2	1	DATA0-
4	3	DATA1-
6	5	DATA2-
8	7	DATA3-
10	9	DATA4-
12	11	DATA5-
14	13	DATA6-
16	15	DATA7-
18	17	Spare
20	19	Spare
22	21	Spare
24	23	Spare
26	25	Spare
28	27	Spare
30	29	Spare
32	31	Spare
34	33	Spare
36	35	BUSY-
38	37	ACK-
40	39	RST-
42	41	MSG-
44	43	SEL-
46	45	C-/D
48	47	REQ-
50	49	I-/O

**TABLE 2-8
CONNECTOR P1, POWER SUPPLY, PIN ASSIGNMENTS**

<u>Pin Number</u>	<u>Voltage</u>
1	+12 Vdc
2	Ground return
3	Ground return
4	+5 Vdc

CHAPTER 3 BOARD SETUP

3.1 GENERAL

This chapter contains the information for setting up and installing the controller before placing it in operation. These preparatory steps require the proper placement of jumpers, mounting the controller in its operating environment, and properly connecting the cables. In addition, the user has the option of using more than one controller with the host adapter in his system. Instructions for connecting multiple controllers appear later in the chapter.

3.2 BOARD SETUP

Setting up the Controller for operation requires checking that the factory-installed jumpers are according to the listing in Table 3-1. Figure 3-1 shows the locations of the jumpers on the Controller.

TABLE 3-1 JUMPER LOCATIONS

<u>Designation</u>	<u>Function</u>	<u>Connection and Result</u>
W1	Factory test	Must be installed
W2	Factory test	Must be installed
W3	Selects sector size	SS to 2: 256-byte sector 32 Sectors/Track SS to 5: 512-byte sector 17 Sectors/Track

3.3 MOUNTING CONTROLLER

The controller board has four mounting holes. It can be mounted anywhere within the drive enclosure so long as it receives airflow.

3.4 CONNECTING CABLES

Before the controller can be placed in operation, the cables to the drive and host must be connected. These cables are listed below:

J1	Control Cable (controller to last drive): maximum 20 feet
J2	Data Cable: maximum 20 feet
J3	Data Cable: maximum 20 feet (optional second drive)
P1	Power Cable
P2	Host Interface Cable: maximum 15 feet

NOTE: Do not attempt to connect a cable to connector J4. Connector J4 is for factory test only.

Figure 3-1 shows the connector locations.

3.5 MULTIPLE CONTROLLERS

A separate Controller is required for each additional pair of drives. Figure 3-2 shows two operating setups; (A) using one Controller and (B) using two Controllers. Notice the terminator (resistor pack) in both drawings. The terminator is at position 5J on the board; when multiple Controllers are used, the terminator must be installed only in the last board in the daisy chain.

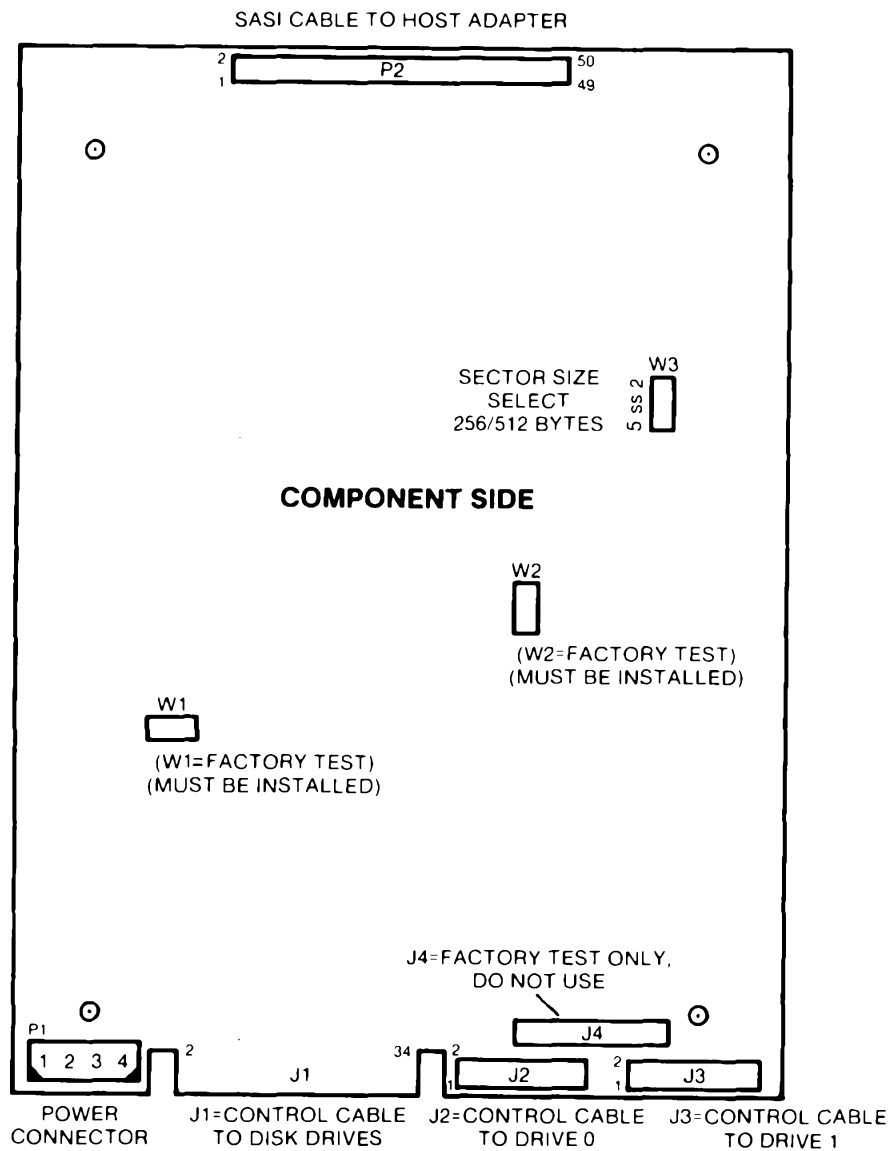
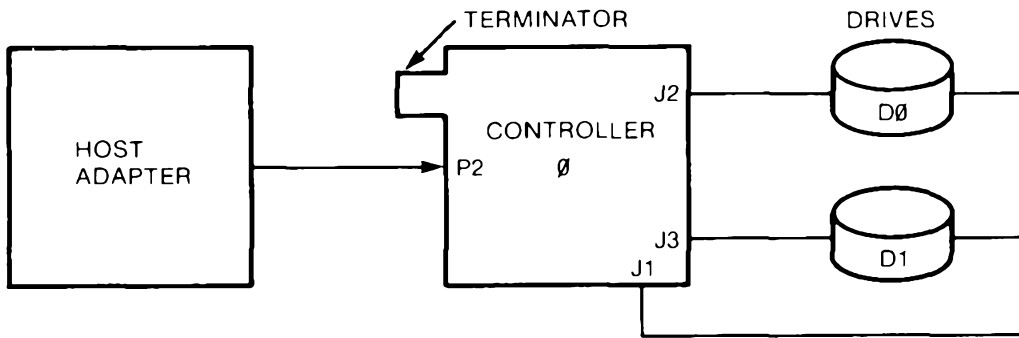
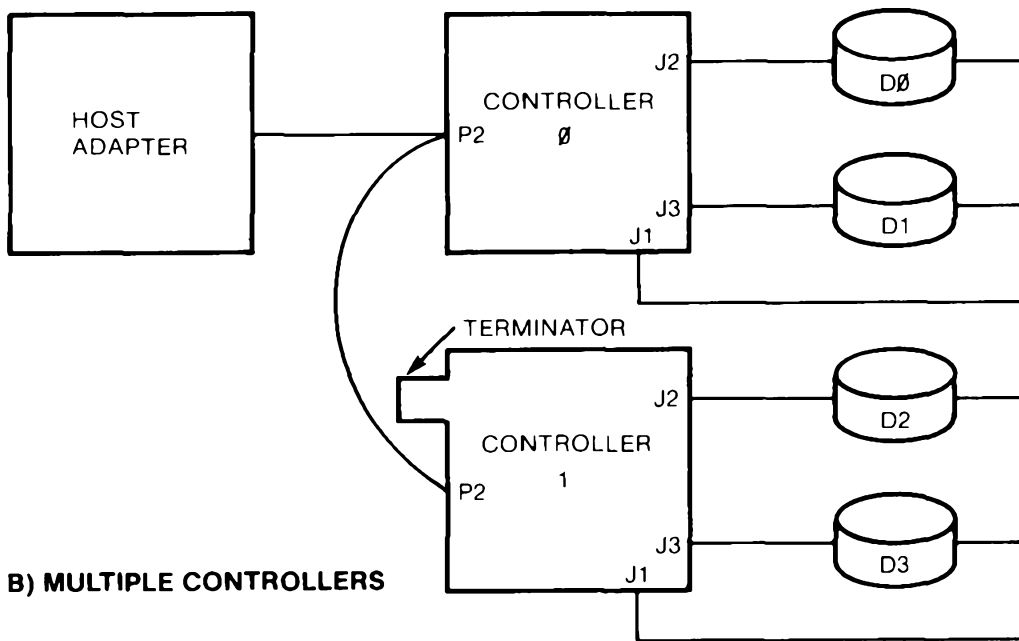

FIGURE 3-1 CABLE, CONNECTOR, AND JUMPER LOCATIONS



A) ONE CONTROLLER



B) MULTIPLE CONTROLLERS

FIGURE 3-2 OPERATING SETUPS

3.6 ADDRESS JUMPER GROUP

The Controller supports one of eight unique device addresses. When more than one Controller is used in a system, the address jumper on the Controller must be changed. Figure 3-3 shows the address jumper group located next to the terminator at position 5J; it also shows that terminal (pad) 0 is connected to terminal S. This is the factory-installed jumper, and it sets the Controller's address to 0.

In order to change this address, the factory-installed jumper (trace) must be cut. Then, a new jumper must be connected between terminal S and the selected address terminal. Figure 3-4 shows that the factory-installed jumper has been cut, and a new jumper has been installed between terminal S and address terminal 1. The address of the Controller is now 1.

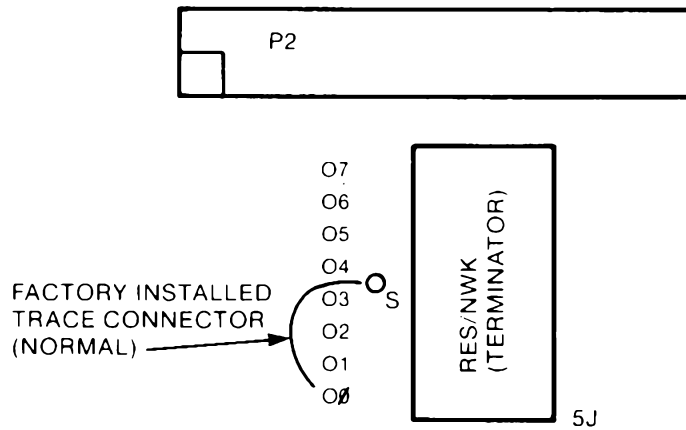

FIGURE 3-3 NORMAL (FACTORY-INSTALLED) ADDRESS JUMPER

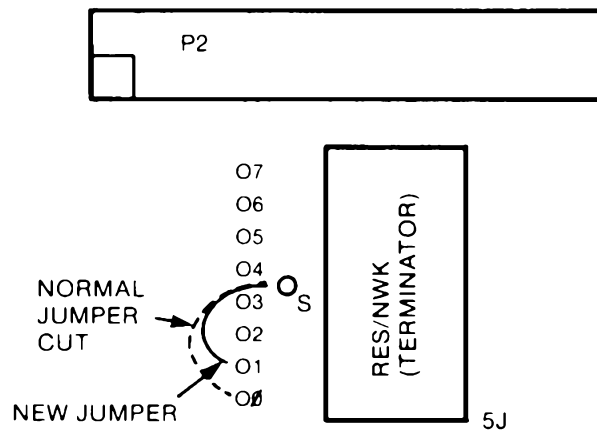

FIGURE 3-4 CHANGED ADDRESS JUMPER (CONTROLLER 1)

CHAPTER 4 THEORY OF OPERATION

4.1 GENERAL

This chapter discusses the theory of operation of the S1410 Controller and lays down the guidelines that will enable the user to use the Controller successfully in any number of applications.

4.1.1 Conventions

Signals or lines can be active in either a high or low state. The terms signal, signal lines, and lines mean the same thing. A low state is equivalent to a voltage level of 0.8 volts or less, and a high state is equivalent to a voltage level of 2.4 volts or more. Some texts use the term 'asserted' to mean active. In this manual, only the term active is used; if the term 'asserted' appears, it is only for reference.

4.1.2 Name and Abbreviations

The dash (-), or the lack of one, indicates the active state of a signal. The active state of a signal is that state which is required for a given operation. When a dash is appended to the end of a signal name, the signal is active when it is low. When no dash appears at the end of a signal name, the signal is active when it is high. Some signal lines have two so-called active (or significant) states. When the level on the line is high, a particular operation takes place. When the level on the line is low, a different operation takes place. The following examples show the use of these conventions.

BUSY- The signal BUSY- is active when it is at low level because it has the dash appended.

BUSY The signal BUSY is active at a high level because it does not have the dash appended.

C-/D The line C-/D (command-/data) has a dual purpose; the slash (/) indicates quality. The dash after the C indicates that when this line is at a low level, command mode is indicated and when it is at a high level, data mode is indicated.

Other designations used to define signal lines are listed below.

Drv	Driver
Rcvr	Receiver
OC	Open collector
Tri-State	Line has three states: high, low, high impedance
220/330	Line termination: 220 Ohms to source voltage/330 Ohms to ground.

4.1.3 Signal Definitions

The following tables list and define the signals that appear on the SASI Bus lines between the host adapter and the controller.

TABLE 4-1 HOST BUS STATUS SIGNALS

<u>NAME</u>	<u>DRV/RCVR</u>	<u>DEFINITION</u>
I-/O	Drv OC	Input-/Output: The controller drives this line. A low level

on this line indicates that the controller is driving the data in on the host bus. A high level on this line indicates that the host adapter is driving the data out on the host bus. The host adapter monitors this line and uses it to enable and disable its data bus drivers. This signal is qualified by signal REQ-.

C-/D	Drv OC	Command-/Data: This signal line indicates whether the information on the data bus consists of command or data bytes. A low means command bytes; a high means data bytes. This signal is qualified by signal REQ-.
BUSY-	Drv OC	Busy: The controller generates this active low signal in response to the SEL-signal and the address bit (DB0-to DB7-) from the host adapter. The busy signal informs the host adapter that the controller is ready to conduct transactions on the host bus.
MSG-	Drv OC	Message: The controller sends this active low signal to the host adapter to indicate that the current command has been completed. When MSG-is active, the I-/O signal line is always low so that the controller can drive the bus data lines. This signal is qualified by signal REQ-.

TABLE 4-2 SUMMARY OF HOST BUS STATUS SIGNALS

<u>I-/O</u>	<u>C-/D</u>	<u>MSG-</u>	<u>DEFINITION</u>
High	Low	High	The controller receives command from the host adapter.
High	High	High	The controller receives data from the host adapter.
Low	High	High	The controller sends data to the host adapter.
Low	Low	High	The controller sends error status byte to the host adapter.
Low	Low	Low	The controller informs the host adapter that it has completed the current command.

TABLE 4-3 CONTROLLER - HOST HANDSHAKING

<u>NAME</u>	<u>DRV/RCVR</u>	<u>DEFINITION</u>
REQ-	Drv OC	Request: The controller sends this active low signal to the host adapter for each byte transferred across the interface. This signal qualifies signals I-/O, C-/D and MSG-.
ACK-	Rcvr, 220/330	Acknowledge: The host adapter generates this active low signal in response to the REQ-signal from the controller when the host is ready to receive or transmit a byte of data. In order to complete the handshake, the host adapter must send an acknowledge (ACK-) in response to each request (REQ-) from the controller.

TABLE 4-4 HOST BUS CONTROL SIGNALS

<u>NAME</u>	<u>DRV/RCVR</u>	<u>DEFINITION</u>
RST-	Rcvr, 220/220	Reset: The host adapter sends this active low signal to the controller to force the controller to the idle state. After

RST-has become active, any controller status is cleared. RST-also causes the deactivation of all signals to the drives. The time requirement for the RST-signal are as follows:

	<u>Minimum</u>	<u>Maximum</u>
	100 nsec.	None
SEL-	Rcvr, 220/330	Select: The host adapter sends this active low signal to the controller to initiate a command transaction. Along with SEL-, the host adapter must also send an address bit to select the controller (DB0- for controller). The controller must not be busy. The host adapter must deactivate SEL- before the end of the current command.

TABLE 4-5 HOST BUS DATA SIGNALS

<u>NAME</u>	<u>DRV/RCVR</u>	<u>DEFINITION</u>
DB7- to	Tri-State,	These are the eight data bits (lines) of the host bus (DB0 = LSB).
DB0-	220/330	Each line is also used as address bits to select a controller in systems using multiple controllers (see Chapter 3). The normal connection (hardwired on the board) is to DB0-which is the address of controller 0. Any other connection requires cutting the existing trace on the board and adding a jumper.

The following list show the bit assignments.

- DB0- Controller 0
- DB1- Controller 1
- DB2- Controller 2
- DB3- Controller 3
- DB4- Controller 4
- DB5- Controller 5
- DB6- Controller 6
- DB7- Controller 7

4.2 BASIC OPERATING CONFIGURATION

The basic operating configuration consists of a host adapter, S1410 Controller, and a Winchester disk drive with an interface that is compatible with that of the Seagate Technology ST506 disk drive. Figure 4-1 shows the basic setup. Also shown is an additional, optional drive; the controller can control a maximum of two drives.

The host can be one of a number of computer systems; the host adapter is an interface between the host's bus and the controller.

4.3 DETAILED DESCRIPTION (HANDSHAKING AND TIMING)

The following paragraphs describe the interaction between the controller and the host adapter.

4.3.1 Controller Selection

Before the host adapter can begin a transaction, it must select the controller. The host adapter selects the controller by activating the SEL-control signal and the address bit of the controller. Any bit,

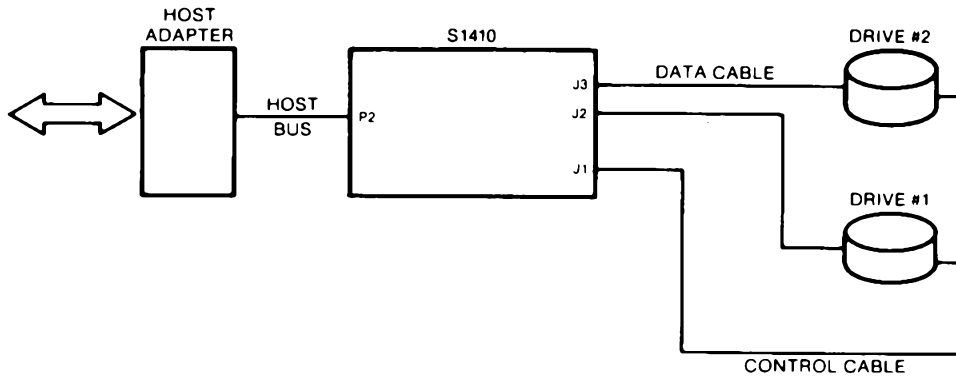

FIGURE 4—1 BASIC OPERATING CONFIGURATON

DB0- through DB7-, can be the address bit in a system with multiple controllers (all controllers leave the factory with DB0- connected to the controller's address logic). For this discussion, the controller's address is 0.

The timing diagram in Figure 4-2 shows the basic timing requirements. Upon receiving both the SEL- signal and DB0-, the controller activates the BUSY-signal. As shown in the timing diagram, both SEL- and DB0- must be active (low) before the controller can activate the BUSY- signal. During the selection process, the host has control of the data bus as signified by the deactivation of the I-/O line. Selection is complete when BUSY- becomes active. The SEL- signal must be deactivated by the host interface before the current controller operation has completed. It is recommended that the SEL- line be deactivated at or before the time the first command byte is sent to the controller. The controller then enters the command mode.

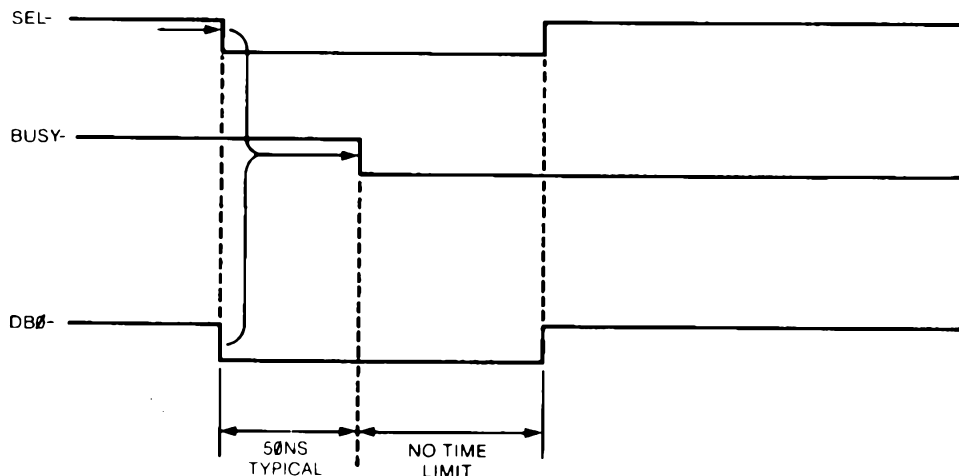

FIGURE 4-2 CONTROLLER SELECT TIMING

4.3.2 Command Mode

The controller receives commands from the host adapter using a handshaking sequence. The controller places a low level on the

C-/D (command-/data) line to indicate that it wants a command from the host adapter and places a high level on the I-/O line to indicate that the movement of information is from the host adapter out to the controller. The MSG-line is high.

The controller activates the REQ- line within 10 microseconds after signals I-/O, C-/D and MSG- have been placed at high, low and high levels, respectively. The host adapter responds by activating the ACK- signal when a command byte is ready for the controller. The command byte placed on the data bus by the host must be stable within 250 nanoseconds after the ACK- signal is activated. The command byte must be held stable until REQ- is deactivated. The host deactivates ACK- after REQ- goes high. This completes the handshake for the first command byte. Each succeeding command byte from the host adapter requires the same complete handshake sequence. See Figure 4-4 for data bus, REQ-, and ACK-timing. See Table 4-2 for I-/O, C-/D and MSG- definition.

4.3.3 Data Transfer

The timing diagrams in Figures 4-3 and 4-4 illustrate the required timing for data transfer. See Table 4-2 for I-/O, C-/D and MSG-definition.

4.3.4 Status Bytes

Two bytes of status are passed to the host at the end of all commands. The first byte informs the host if any errors occurred during the execution of the command. The second is a zero byte. It signals to the host that the command is complete. Figure 4-3 shows the data bus, REQ- and ACK- timing. See Table 4-2 for I-/O, C-/D and MSG-definition. Figure 4-5a shows the format of these two bytes.

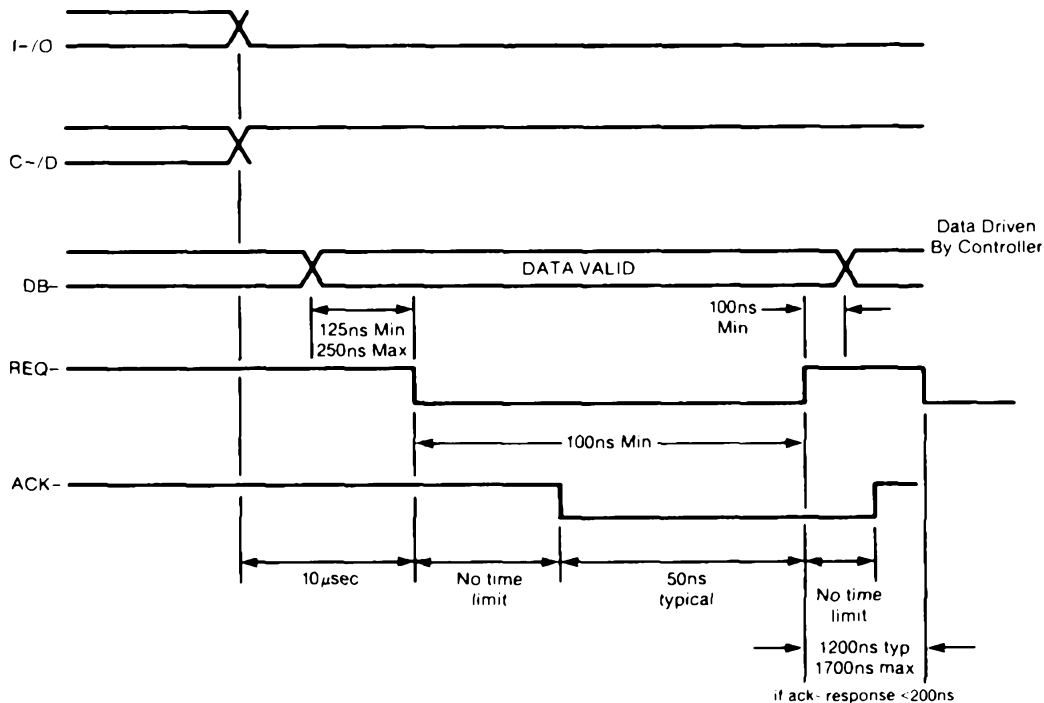

FIGURE 4-3 DATA TRANSFER TO HOST, TIMING

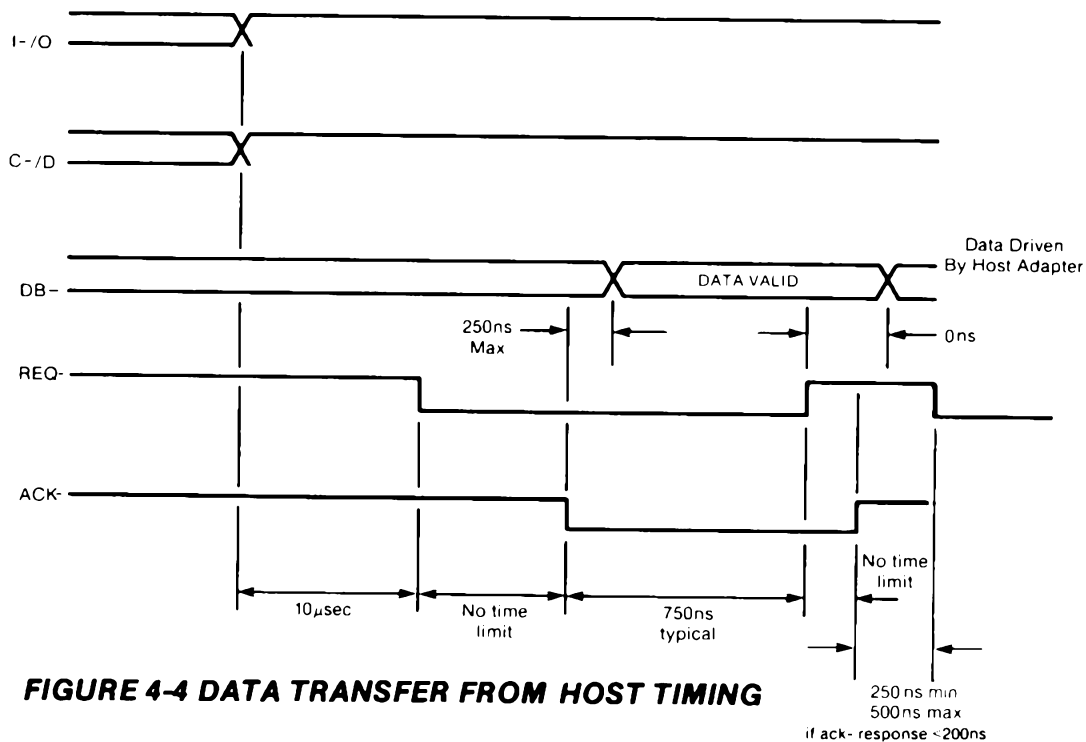

FIGURE 4-4 DATA TRANSFER FROM HOST TIMING

4.4 PROGRAMMING INFORMATION

The following section discusses communications between the controller and host from the point of view of the codes that are passed. The host sends commands to the controller through the host adapter. The controller then performs the commands and reports back to the host.

4.5 COMMANDS

The host sends a six-byte block to the controller to specify the operation. This block is the Device Control Block (DCB). Figure 4-5 shows the composition of the DCB. The list that follows Figure 4-5 defines the bytes that make up the DCB.

At the end of a command, the controller returns two completion status bytes to the host. The format of these bytes is shown in Figure 4-5a.

Bit	7	6	5	4	3	2	1	0
Byte 0	Cmd class			Opcode				
Byte 1	LUN			High Address				
Byte 2	Middle Address							
Byte 3	Low Address							
Byte 4	Interleave or Block Count							
Byte 5	Control Field							

FIGURE 4-5 DEVICE CONTROL BLOCK (DCB) FORMAT

- Byte 0 Bits 7, 6 and 5 identify the class of the command. Bits 4 through 0 contain the opcode of the command.
- Byte 1 Bits 7, 6 and 5 identify the logical unit number (LUN). Bits 4 through 0 contain logical disk address 2.

Byte 2 Bits 7 through 0 contain logical disk address 1.
 Byte 3 Bits 7 through 0 contain logical disk address 0 (LSB).
 Byte 4 Bits 7 through 0 specify the interleave or block count.
 Byte 5 Bits 7 through 0 contain the control field.

Next to Last Status Byte

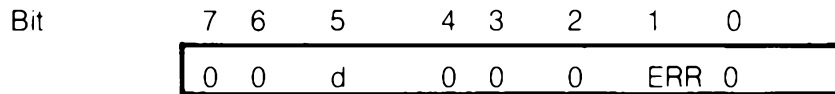

Bits 0, 2-4,6,7 Set to zero.
 Bit 1 When set, error occurred during command execution.
 Bit 5 Logical unit number of drive, d=0 or 1.

Last Status Byte

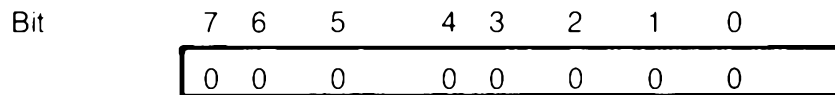

Bits 0-7 Set to zero.

FIGURE 4-5A COMPLETION STATUS BYTES

4.5.1 Control Byte

The control field, byte 5, of the DCB allows the user to select options for several different types and makes of disk drives. The following list defines the bits of the control byte.

Bit 0 Half-step option of Seagate and Texas Instrument drives.
 Bit 1 Half-step option for Tandon drives.
 Bit 2 Buffer-step option for drives made by Computer Memories, Inc. and Rotating Memories, Inc. (200 microsecond pulse per step).
 Bit 3-5 Spare. Set to zero for future use.
 Bit 6 If one, during a read sector command, the failing sector is not re-read on the next revolution before attempting correction. This bit should be set to zero for normal operation.
 Bit 7 Disable the four retries by the controller on all disk-access commands. Set this bit only during the evaluation of the performance of a disk drive. This bit should be set to zero for normal operation.

NOTE: The step option bits (2-0) are mutually exclusive and only one option should be selected in any given configuration.

4.5.2 Logical Address (High, Middle and Low)

The logical address of the drive is computed by using the following equation.

$$\text{Logical Address} = (\text{CYADR} \cdot \text{HDCYL} + \text{HDADR}) \cdot \text{SETRK} + \text{SEADR}$$

Where: CYADR = Cylinder Address
 HDADR = Head Address
 SEADR = Sector Address
 HDCYL = Number of Heads per Cylinder
 SETRK = Number of Sectors per Track

The commands fall into eight classes, 0 through 7; only classes 0 and 7 are used. Class 0 commands are data, non-data transfer, and status commands. Classes 1 through 6 are reserved. Class 7 are diagnostic commands.

Each command is described below. The description includes its class, opcode, and format. When a slash (/) represents a bit position, the slash means that the value of that bit is not important (a don't-care bit).

4.5.3 Test Drive Ready (Class 0, Opcode 00)

This command selects a particular drive and verifies that the drive is ready. The following diagram shows the format of the device control block for this command.

d = drive, 0 or 1

Bit	7	6	5	4	3	2	1	0
Byte 0	0	0	0	0	0	0	0	0
Byte 1	0	0	d	/	/	/	/	/
Byte 2	/	/	/	/	/	/	/	/
Byte 3	/	/	/	/	/	/	/	/
Byte 4	/	/	/	/	/	/	/	/
Byte 5	/	/	/	/	/	/	/	/

4.5.4 Recalibrate (Class 0, Opcode 01)

This command positions the read/write (R/W) arm to track 00.

d = drive, 0 or 1

r = retries

s = step option

Bit	7	6	5	4	3	2	1	0
Byte 0	0	0	0	0	0	0	0	1
Byte 1	0	0	d	/	/	/	/	/
Byte 2	/	/	/	/	/	/	/	/
Byte 3	/	/	/	/	/	/	/	/
Byte 4	/	/	/	/	/	/	/	/
Byte 5	r	0	0	0	0	s	s	s

4.5.5 Reserved (Class 0, Opcode 02)

This opcode is not used.

4.5.6 Request Sense Status (Class 0, Opcode 03)

The host must send this command immediately after it detects an error. The command causes the Controller to return four bytes of drive and Controller status; the formats of these four bytes are shown after the DCB. When an error occurs on a multiple sector data transfer, (read or write), the Request Sense Status command returns the logical address of the failing sector in bytes 1, 2 and 3. If the Request Sense Status command is issued after any of the Format commands or the Check Track Format command, then the logical address returned by the controller points to one sector beyond the last track formatted or checked if there was no error. If there was an error, then the logical address returned points to the track in error. The tables that follow the formats list the error codes.

d = drive, 0 or 1

Bit	7	6	5	4	3	2	1	0
Byte 0	0	0	0	0	0	0	1	1
Byte 1	0	0	d	/	/	/	/	/
Byte 2	/	/	/	/	/	/	/	/
Byte 3	/	/	/	/	/	/	/	/
Byte 4	/	/	/	/	/	/	/	/
Byte 5	/	/	/	/	/	/	/	/

SENSE BYTES

Bit	7	6	5	4	3	2	1	0
Byte 0	SEE BELOW							

Bits 0-3	Error Code
Bits 4-5	Error Type
Bit 6	Spare, set to zero
Bit 7	Address valid, when set

The address valid bit in the error code byte (bit 7) is relevant only when the previous command required a logical block address; in which case it is always returned as a one otherwise it is set to zero. For instance, if a Recalibrate command is followed immediately by a Request Sense Status command, the address valid bit would be returned as zero since this command does not require a logical block address to be passed in its DCB.

Bit	7	6	5	4	3	2	1	0
Byte 1	0	0	d	High Address				
Byte 2	Middle Address							
Byte 3	Low Address							

d = drive, 0 or 1

TABLE 4-6 TYPE 0 ERROR CODES, DISK DRIVE

<u>HEX CODE</u>	<u>DEFINITION</u>
0	The controller detected no error during the execution of the previous operation.
1	The controller did not detect an index signal from the drive.
2	The controller did not get a seek complete signal from the drive after seek operation.
3	The controller detected a write fault from drive during last operation.
4	After the controller selected the drive, the drive did not respond with ready signal.
5	Not used.
6	After stepping maximum number of cylinders, controller did not receive track 00 signal from the drive.

TABLE 4-7 TYPE 1 ERROR CODES, CONTROLLER

<u>HEX CODE</u>	<u>DEFINITION</u>
0	ID Read Error: The controller detected an ECC error in the target ID field on the disk.
1	Data Error: The controller detected an uncorrectable ECC error in the target sector during a read operation.
2	Address Mark: The controller did not detect the target address mark (AM) on the disk.
3	Not used.
4	Sector Not Found: The controller found the correct cylinder and head, but not the target sector.
5	Seek Error: The controller detected an incorrect cylinder or track, or both.
6	Not used.
7	Not used.
8	Correctable Data Error: The controller detected a correctable ECC error in the target data field.
9	Bad Track: The controller detected the bad track flag during the last operation.
A	Format Error: During a check-track command, the controller detected one of the following: 1) track not formatted 2) wrong interleave 3) ID ECC error on at least one (1) sector

**TABLE 4-8
TYPES 2 AND 3 ERROR CODES, COMMAND AND MISCELLANEOUS**

<u>HEX CODE</u>	<u>TYPE</u>	<u>DEFINITION</u>
0	2	Invalid Command: The controller has received an invalid command from the host.
1	2	Illegal Disk Address: The controller detected an address that is beyond the maximum range.
0	3	RAM Error: The controller detected a data error during the RAM sector buffer diagnostic.
1	3	Program Memory Checksum Error: During its internal diagnostic, the controller detected a program-memory checksum error.
2	3	ECC Polynomial Error: During the controller's internal diagnostic, the hardware ECC generator failed its test.

The following is a summary of the error codes returned as the result of the Request Sense Status command.

NOTE: The address valid bit (bit 7) may or may not be set and is not included here for clarity.

<u>Error Code (hex)</u>	<u>Meaning.</u>
00	No error detected (command completed ok).
01	No index detected from disk drive.
02	No seek complete from disk drive.
03	Write fault from disk drive.
04	Drive not ready after it was selected.
05	Not used.
06	Track 00 not found.
07-0F	Not used.
10	ID field read error.
11	Uncorrectable data error.
12	Address mark not found.
13	Not used.
14	Target sector not found.
15	Seek error.
16-17	Not used.
18	Correctable data error.
19	Bad track flag detected.
1A	Format error.
1B-1F	Not used.
20	Invalid command.
21	Illegal disk address.
22-2F	Not used.
30	Ram diagnostic failure.
31	Program memory checksum error.
32	ECC diagnostic failure.
33-3F	Not used.

4.5.7 Format Drive (Class 0, Opcode 04)

This command formats all sectors with ID and data fields according

to the selected interleave factor. Also, it writes 6C Hex into data fields. The starting address is passed in the DCB. The Controller will format from the starting address to the end of the disk.

d = drive, 0 or 1

r = retries

s = step option

Bit	7	6	5	4	3	2	1	0
Byte 0	0	0	0	0	0	1	0	0
Byte 1	0	0	d	High Address				
Byte 2	Middle Address							
Byte 3	Low Address							
Byte 4	0	0	0	Interleave				
Byte 5	r	0	0	0	0	s	s	s

Interleave:

1 to 31 for 256 sectors }
 1 to 16 for 512 sectors } Refer to Section 4.10

4.5.8 Check Track Format (Class 0, Opcode 05)

This command checks the format on the specified track for correct ID and interleave. The command does not read the data field.

d = drive, 0 or 1

r = retries

s = step option

Bit	7	6	5	4	3	2	1	0
Byte 0	0	0	0	0	0	1	0	1
Byte 1	0	0	d	High Address				
Byte 2	Middle Address							
Byte 3	Low Address							
Byte 4	0	0	0	Interleave				
Byte 5	r	0	0	0	0	s	s	s

Interleave:

1 to 31 for 256 sectors }
 1 to 16 for 512 sectors } Refer to Section 4.10

4.5.9 Format Track (Class 0, Opcode 06)

This command formats a specified track and can be used to clear bad-sector flag in all sectors on the specified track that was

previously formatted with the Format Bad Track command. The command writes 6C Hex into all data fields.

d = drive, 0 or 1
 r = retries
 s = step option

Bit	7	6	5	4	3	2	1	0
Byte 0	0	0	0	0	0	1	1	0
Byte 1	0	0	d	High Address				
Byte 2	Middle Address							
Byte 3	Low Address							
Byte 4	0	0	0	Interleave				
Byte 5	r	0	0	0	0	s	s	s

Interleave:

1 to 31 for 256 sectors }
 1 to 16 for 512 sectors } Refer to Section 4.10

4.5.10 Format Bad Track (Class 0, Opcode 07)

This command formats the specified track and sets the bad-sector flag in the ID fields. It does not write the data fields.

d = drive, 0 or 1
 r = retries
 s = step option

Bit	7	6	5	4	3	2	1	0
Byte 0	0	0	0	0	0	1	1	1
Byte 1	0	0	d	High Address				
Byte 2	Middle Address							
Byte 3	Low Address							
Byte 4	0	0	0	Interleave				
Byte 5	r	0	0	0	0	s	s	s

Interleave:

1 to 31 for 256 sectors }
 1 to 16 for 512 sectors } Refer to Section 4.10

4.5.11 Read (Class 0, Opcode 08)

This command reads the specified number of sectors, starting with the initial sector address contained in the DCB.

d = drive, 0 or 1
 r = retries
 a = retry option on data ECC error
 s = step option

Bit	7	6	5	4	3	2	1	0
Byte 0	0	0	0	0	1	0	0	0
Byte 1	0	0	d	High Address				
Byte 2	Middle Address							
Byte 3	Low Address							
Byte 4	Block Count							
Byte 5	r	a	0	0	0	s	s	s

4.5.12 Reserved (Class 0 Opcode 09)

This opcode is not used.

4.5.13 Write (Class 0, Opcode 0A)

This command writes the specified number of sectors, starting with the initial sector address contained in the DCB. Each sector of data can be either 256 or 512 bytes long. The sector size is jumper selectable, see Chapter 3.

d = drive, 0 or 1

r = retries

s = step option

Bit	7	6	5	4	3	2	1	0
Byte 0	0	0	0	0	1	0	1	0
Byte 1	0	0	d	High Address				
Byte 2	Middle Address							
Byte 3	Low Address							
Byte 4	Block Count							
Byte 5	r	0	0	0	0	s	s	s

4.5.14 Seek (Class 0, Opcode 0B)

This command initiates a seek to the track specified in the DCB. The drive must be formatted.

d = drive, 0 or 1

r = retries

s = step option

Bit	7	6	5	4	3	2	1	0
Byte 0	0	0	0	0	1	0	1	1
Byte 1	0	0	d	High Address				
Byte 2	Middle Address							
Byte 3	Low Address							
Byte 4	/	/	/	/	/	/	/	/
Byte 5	r	0	0	0	0	s	s	s

4.5.15 Initialize Drive Characteristics (Class 0, Opcode 0C)

This command enables the user to configure the Controller to work with drives that have different capacities and characteristics. However, both drive 0 and drive 1 must be of the same manufacturer and model number.

After the host sends the command (DCB) to the controller, it then sends an eight-byte block of data that contains the drive parameters. Some of the parameters occupy two bytes; all two-byte parameters are transferred with the most significant byte (MSB) first. The eight bytes are listed below.

- C= Maximum number of cylinders (2 bytes)
- H= Maximum number of heads (1 byte)
- W= Starting reduced write current cylinder (2 bytes)
- P= Starting write precompensation cylinder (2 bytes)
- E= Maximum ECC data burst length (1 byte)

When the controller is powered up or reset, the default values listed below are set.

- Maximum number of cylinders = 153
- Maximum number of heads = 4
- Starting reduced write current cylinder = 128
- Starting write precompensation cylinder = 64
- Maximum ECC data burst length = 11 bits

The configuration parameters for various disk drives can be found at the beginning of Appendix A in the back of this manual.

The parameter for the maximum ECC burst length defines the length of a burst error in the data field that the controller will correct. The burst length is defined as the number of bits from first error bit to the last error bit. For example, the controller detected a 5-bit ECC error and the erroneous data appeared as C5 (1100 0101) before correction and could appear as D4 (1101 0100) after the correction. However, if the host has set the maximum ECC burst length at 4 bits, the controller would have to flag this data as uncorrectable. This is a type 1, code 1 error.

Command Bytes

Bit	7	6	5	4	3	2	1	0
Byte 0	0	0	0	0	1	1	0	0
Byte 1	/	/	/	/	/	/	/	/
Byte 2	/	/	/	/	/	/	/	/
Byte 3	/	/	/	/	/	/	/	/
Byte 4	/	/	/	/	/	/	/	/
Byte 5	/	/	/	/	/	/	/	/

Parameter Bytes

Bit	7	6	5	4	3	2	1	0
Byte 0	C	C	C	C	C	C	C	C
Byte 1	C	C	C	C	C	C	C	C
Byte 2	0	0	0	0	H	H	H	H
Byte 3	W	W	W	W	W	W	W	W
Byte 4	W	W	W	W	W	W	W	W
Byte 5	P	P	P	P	P	P	P	P
Byte 6	P	P	P	P	P	P	P	P
Byte 7	0	0	0	0	E	E	E	E

4.5.16 Read ECC Burst Error Length (Class 0, Opcode 0D)

This command transfers one byte to the host. This byte contains the value of the ECC burst length that the controller detected during the last Read command. This byte is valid only after a correctable ECC data error, type 1, code 8.

Bit	7	6	5	4	3	2	1	0
Byte 0	0	0	0	0	1	1	0	1
Byte 1	/	/	/	/	/	/	/	/
Byte 2	/	/	/	/	/	/	/	/
Byte 3	/	/	/	/	/	/	/	/
Byte 4	/	/	/	/	/	/	/	/
Byte 5	/	/	/	/	/	/	/	/

4.5.17 RAM Diagnostic (Class 7, Opcode 00)

This command performs a data pattern test on the RAM buffer.

Bit	7	6	5	4	3	2	1	0
Byte 0	1	1	1	0	0	0	0	0
Byte 1	/	/	/	/	/	/	/	/
Byte 2	/	/	/	/	/	/	/	/
Byte 3	/	/	/	/	/	/	/	/
Byte 4	/	/	/	/	/	/	/	/
Byte 5	/	/	/	/	/	/	/	/

4.5.18 Reserved (Class 7, Opcode 01)

This opcode is not used.

4.5.19 Reserved (Class 7, Opcode 02)

This opcode is not used.

4.5.20 Drive Diagnostic (Class 7, Opcode 03)

This command tests both the drive and the drive-to-controller interface. The controller sends recalibrate and seek commands to the selected drive and verifies sector 0 of all the tracks on the disk. The controller does not perform any write operations during this command; it is assumed that the disk has been previously formatted.

Bit	7	6	5	4	3	2	1	0
Byte 0	1	1	1	0	0	0	1	1
Byte 1	0	0	d	/	/	/	/	/
Byte 2	/	/	/	/	/	/	/	/
Byte 3	/	/	/	/	/	/	/	/
Byte 4	/	/	/	/	/	/	/	/
Byte 5	r	0	0	0	0	s	s	s

4.5.21 Controller Internal Diagnostics (Class 7, Opcode 04)

This command causes the controller to perform a self-test. The controller checks its internal processor, data buffers, ECC circuitry, and the checksum of the program memory. The controller does not access the disk drive.

Bit	7	6*	5	4	3	2	1	0
Byte 0	1	1	1	0	0	1	0	0
Byte 1	/	/	/	/	/	/	/	/
Byte 2	/	/	/	/	/	/	/	/
Byte 3	/	/	/	/	/	/	/	/
Byte 4	/	/	/	/	/	/	/	/
Byte 5	/	/	/	/	/	/	/	/

4.5.22 Read Long (Class 7, Opcode 05)

This command transfers the target sector and four bytes of data ECC to the host. If an ECC error occurs during the read, the controller does not attempt to correct the data field. This command is useful in recovering data from a sector that contains an uncorrectable ECC error. It is also useful during diagnostic operations.

d = drive, 0 or 1

r = retries

s = step option

Bit	7	6	5	4	3	2	1	0
Byte 0	1	1	1	0	0	1	0	1
Byte 1	0	0	d	High Address				
Byte 2	Middle Address							
Byte 3	Low Address							
Byte 4	Block Count							
Byte 5	r	0	0	0	0	s	s	s

4.5.23 Write Long (Class 7, Opcode 06)

This command transfers a sector of data and four appended ECC bytes to the disk drive. During this write operation, the host supplies the four ECC bytes instead of the usual hardware-generated ECC bytes. This command is useful only for diagnostic operations.

d = drive, 0 or 1

r = retries

s = step option

Bit	7	6	5	4	3	2	1	0
Byte 0	1	1	1	0	0	1	1	0
Byte 1	0	0	d	High Address				
Byte 2	Middle Address							
Byte 3	Low Address							
Byte 4	Block Count							
Byte 5	r	0	0	0	0	s	s	s

4.6 SECTOR FORMAT

Figure 4-6 shows the format of the sector and the names of the fields of the information traveling over the Controller-drive interface. Table 4-9 lists the fields and a description of each field.

TABLE 4-9 SECTOR FIELD DESCRIPTION

FIELD	BYTES	FIELD DESCRIPTION
AM	4	Address Mark
GAP1	9	Zero Byte Gap
SYNC1	1	ID Sync Byte
GAP2	2	ID Zero Byte Gap
COM	1	ID Compare Byte
CYLH	1	Cylinder High (MSB)
CYLL	1	Cylinder Low (LSB)
HEAD	1	Head Number
SEC	1	Sector Number
FLAG	1	Flag Byte
ZER	1	Zero Byte
ECC1	4	ID ECC Bytes

TABLE 4-9 SECTOR FIELD DESCRIPTION (con't)

FIELD	BYTES	FIELD DESCRIPTION
GAP3	16	Zero Byte Gap
SYNC2	1	Data Field Sync Byte
GAP4	2	Data Field Zero Byte Gap
DATA	256/512	Data Field
ECC2	4	Data Field Ecc Bytes
GAP5	14/43	Inter-record Zero Gap

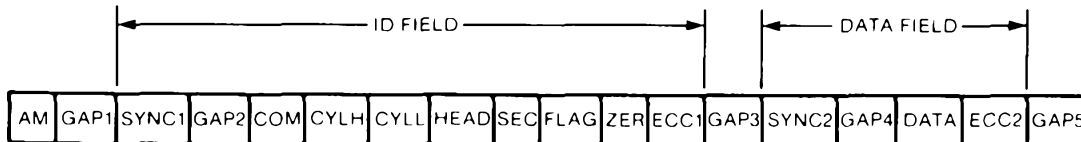

FIGURE 4-6 SECTOR FORMAT

4.7 EXECUTION OF DIAGNOSTICS

Since all of the diagnostics are not executed by the controller on power up, it is suggested that they be invoked by the host in the following order:

- 1) Controller internal diagnostics (Command code E4). This diagnostic tests all the logical and decision making capability of the controller as well as the program memory checksum and the error detection and correction circuits (ECC). Execution of this diagnostic ensures that the controller can communicate with the host.
- 2) Ram Diagnostic (Command code E0) should be executed next. This command verifies that the sector buffer is operational by writing, reading and verifying various data patterns to and from all locations.
- 3) If the parameters of the connected drives are different than the default parameters, see Section 4.5.15, the new configuration must be sent to the controller using the Initialize Drive Characteristics command (Command code 0C) before the Drive Diagnostic is executed. (See appendix A for the configuration parameters of various disk drives).
- 4) Before the Drive Diagnostic is executed, the host program should continuously issue a Test Drive Ready command to the controller (Command code 00) with the appropriate time-out until the drive becomes ready.
- 5) Drive Diagnostic (Command code E3). This diagnostic issues a Recalibrate to the disk drive and then steps through all tracks verifying the ECC on the identifier fields of the first sector of each track. If this diagnostic passes, it implies that the disk has been formatted and that the first ID field of each track is good.

4.8 ERROR CORRECTION PHILOSOPHY

Since the typical error correction time of the S1410 controller is approximately 50 milliseconds and therefore greater than the time for one revolution of the disk, the sector in error is optionally re-read (if bit 6 is not set in byte 5 of the read command DCB) on the next revolution during a Read command. In most

cases, the error will be soft and will not reappear on the re-read. This initial re-read of the failing sector is over and above the retry count passed in the DCB (bit 7, byte 5).

The retry count on errors is preset to 4 by the controller each time a sector has been read successfully. On a multiple sector transfer if an uncorrectable error was detected but subsequently found to be correctable on a retry, the retry count is reset to 4 before the next sector is read from the disk.

4.9 ALTERNATE TRACK ASSIGNMENT AND HANDLING

The assignment of alternate tracks and the lockout of bad tracks has to be done by the host computer. Bad areas on the disk are labeled defective on a track basis by issuing a Format Bad Track command (Command code 07). One procedure for assignment and handling of alternate tracks might be as follows:

- 1) The entire disk drive is formatted by issuing a Format Disk command (Command code 04) starting at logical track zero.

If an error occurs during formatting then a Request Sense Status command should be issued. If a format error is indicated, bytes 1, 2 and 3 of the returned status gives the address of the bad track and a Format Bad Track command (command code 07) should be issued to that track. A new Format command is then issued to format the rest of the disk starting at one track beyond the bad track. If any other errors occur during the subsequent formatting, the above process should be repeated until the entire disk is formatted.

- 2) A recalibrate command is issued (Command code 01) to position the heads over track 00.
- 3) All sectors on the disk are read to see if any uncorrectable ECC errors have occurred in the data. The Format command places a 6C (hex) pattern in the data fields of all sectors and the host program can optionally verify this data pattern after the data is read into memory, however, verifying the data byte-for-byte is not normally necessary since the Error Detection and correction circuitry flags all uncorrectable errors. If a large block of host memory is available, multiple sector reads can be issued to speed up the verify process.
- 4) When an uncorrectable error is found, a Format Bad Track command (Command code 07) is issued to the failing track which writes a bad track flag into all identifier fields. Whenever this track is subsequently accessed, an error will result and the Sense Status command which follows will indicate an error code 19 (hex). It should be noted that once a track has been flagged as defective, the data fields cannot be accessed.

The host program must maintain a table of bad tracks and the alternates assigned to them. This table can be placed on a known good area of the disk (most manufacturers guarantee certain tracks to be error free).

Whenever a user program accesses the disk, it should not be allowed by the operating system to issue a read or write command to the alternate tracks. The disk controller has no way of knowing when an alternate track is being read.

The alternate tracks are sometimes assigned at the end of the disk (highest track numbers) but they may be assigned to any tracks as long as the track table is maintained by the host.

In general, if four tracks are reserved as alternates, they should be adequate for all disk drives currently available given the error correction capability of the S1410 controller, however, it is recommended that the system programmer consult the disk drive manual for the hard defect specifications.

4.10 SECTOR INTERLEAVING

Variable sector interleaving is supported by the S1410 disk controller. When any format command is issued, any interleave value up to the number of sectors-per-track minus one may be passed in the Device Control Block (DCB byte 4). The interleave factor may be adjusted for maximum system performance. Interleaving allows logical contiguous sectors of data on a given track to be mapped onto non-adjacent physical sectors. An interleave factor of five, for instance means that every fifth physical sector is transferred as the next contiguous logical sector of data. It does not mean that five sectors of data are transferred in one revolution. If the operation is read and the interleave factor is five then a sector of data is read into the sector buffer first and during the time that the heads are passing over the next four physical sectors of the disk, the data is being transferred to the host. If the host cannot transfer the full sector of data during the four sector times available, then the controller has to wait a full revolution before the next logical sector can be read from the disk. If this happens, the interleave factor is too low and should be increased until an increase in operating system speed is noticed.

In order to take full advantage of the interleaving feature of the controller, the operating system should perform multiple sector data transfers. If single sector transfers are employed, the difference in speed with various interleave factors may not be dramatic.

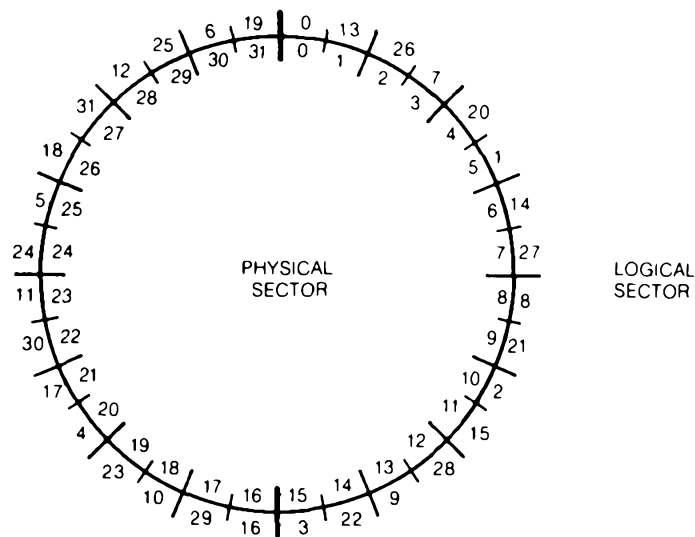

FIGURE 4-10 TRACK FORMAT EXAMPLE OF 32 SECTORS-PER-TRACK WITH AN INTERLEAVE FACTOR OF 5

APPENDIX A

CONFIGURATION PARAMETERS FOR VARIOUS DISK DRIVES

The following is a list of the configuration parameters for various disk drives which are supported by the S1410 disk controller. The table lists the actual values to be passed to the controller in the Initialize Drive Characteristics command (0C). The first value of each entry is in decimal and the value following it in parentheses is its equivalent in hexadecimal. Note that the number of cylinders and heads passed is an absolute value (1 relative) and the reduce write current and write precomposition cylinder values are zero relative.

The abbreviations for the manufacturers are as follows:

CMI	Computer Memories Incorporated.
OLI	Olivetti.
RMS	Rotating Memory Systems Incorporated.
SEA	Seagate Technology Incorporated.
TAN	Tandon Incorporated.
TI	Texas Instruments
RO	Rodime Ltd.
MS	Miniscribe

<u>Mfgr/Model No.</u>	<u>Cylinders</u>	<u>Heads</u>	<u>Reduce Write Cyl.</u>	<u>Write Precomp Cyl.</u>
CMI CM-5205	256 (100)	2	256 (100)	256 (100)
CMI CM-5410	256 (100)	4	256 (100)	256 (100)
CMI CM-5616	256 (100)	6	256 (100)	256 (100)
OLI HD561	180 (B4)	2	128 (80)	180 (B4)
OLI HD562	180 (B4)	2	128 (80)	180 (B4)
RMS 503	153 (99)	2	77 (4B)	77 (4B)
RMS 506	153 (99)	4	77 (4B)	77 (4B)
RMS 512	153 (99)	8	77 (4B)	77 (4B)
SEA ST-506	153 (99)	4	128 (80)	64 (40)
SEA ST-412	306 (132)	4	128 (80)	64 (40)
TAN TM602S	153 (99)	4	128 (80)	153 (99)
TAN TM603S	153 (99)	6	128 (80)	153 (99)
TAN TM603SE	230 (E6)	6	128 (80)	128 (80)
TI 5¼+	153 (99)	4	64 (40)	64 (40)
RO 101	192 (C0)	2	96 (60)	0 (0)
RO 102	192 (C0)	4	96 (60)	0 (0)
RO 103	192 (C0)	6	96 (60)	0 (0)
RO 104	192 (C0)	8	96 (60)	0 (0)
RO 201	321 (141)	2	132 (84)	0 (0)
RO 202	321 (141)	4	132 (84)	0 (0)
RO 203	321 (141)	6	132 (84)	0 (0)
RO 204	321 (141)	8	132 (84)	0 (0)
MS 1-006	306 (132)	2	153 (99)	0 (0)
MS 1-012	306 (132)	4	153 (99)	0 (0)

APPENDIX B

SAMPLE HARDWARE INTERFACE AND PROGRAMMING EXAMPLES FOR A Z-80 BASED MICROPROCESSOR TO INTERFACE TO THE XEBEC S1410 CONTROLLER

SASI read port Function.

0	Read data (from controller to CPU)
1	Read hardware status lines (from cntlr to CPU)
2	Not used
3	Not used

SASI write port Function.

0	Write data (from CPU to controller)
1	Controller reset (and interface reset)
2	Generate controller select pulse
3	Not used

WRITE TRANSPARENT LATCH (DATA FROM HOST).

The data to be sent to the controller is passed through this register when the enable line is high and is latched up when the enable goes low. The latch enable is generated by a programmed I/O write to SASI write port 0 from the host. The positive going (trailing) edge of the negative true I/O write signal from the host also sets the handshake acknowledge flip flop which asserts the acknowledge signal (ACK-) on the SASI bus indicating to the controller that data is available from the host.

WRITE DATA BUS DRIVER (TO THE CONTROLLER).

This is a tri-state bus driver which is enabled to drive the SASI bus under command of the controller when it brings the Input-/Output signal on the SASI bus high.

READ DATA BUS RECEIVER (FROM THE CONTROLLER).

Data or Status from the controller is driven onto the host data bus by a programmed I/O read (SASI read port 0) from the host.

SASI HARDWARE STATUS LINE RECEIVER (FROM CONTROLLER).

The hardware status is driven onto the host data bus when an I/O read is issued by the host program to SASI read port 1. It should be noted that the status signals from the SASI bus are inverted before they are sent to the host.

The bits in the hardware status as seen by the host program are defined as follows:*

Bit Usage

- 7 Not used (MSB).
- 6 Not used.
- 5 Not used.
- 4 Input/Output- signal from the controller.
1 = input from controller to host, 0 = output from host to controller.

- 3 Command/Data- signal from the controller.
1 = Command info on SASI bus, 0 = data on SASI bus.
- 2 Message (MSG-) signal from the controller.
1 = second completion status byte.
- 1 BUSY- signal from the controller.
1 = controller busy.
- 0 Request signal from the controller (REQ-).
1 = transfer request.

***NOTE:** The polarities of these signals do not match those of the S1410 because in this sample circuit they are inverted by the SASI status interface chip.

HANDSHAKE ACKNOWLEDGE FLIP FLOP.

This flip flop is used for all data, command or status handshakes between the host and the controller under programmed I/O control. As long as the controller is not selected, this flip flop is kept directly cleared by the inactive REQ-line which in turn keeps the acknowledge line (ACK-) inactive to the controller.

After the controller is selected and ready to accept a command from the host, it asserts the REQ- line signaling the host to write a command byte into the transparent latch. When the host writes into the latch, the handshake acknowledge flip flop is set signaling the controller that the data is available. When the controller has read the command byte from the SASI bus, it deactivates the REQ-line clearing the handshake acknowledge flip flop, which in turn deactivates the acknowledge line (ACK-).

When the ACK- signal is deasserted, the REQ-signal is again activated by the controller starting the handshake sequence for the next byte.

PROGRAMMING EXAMPLES.

The S1410 controller commands fall into two classes:

- A. Class 0
 - 1) — Non data transfer commands
 - 2) — Data transfer commands
 - 3) — Status command
- B. Class 7
 - 1) — Diagnostics

Before a command is sent, the controller has to be selected.

CONTROLLER SELECTION.

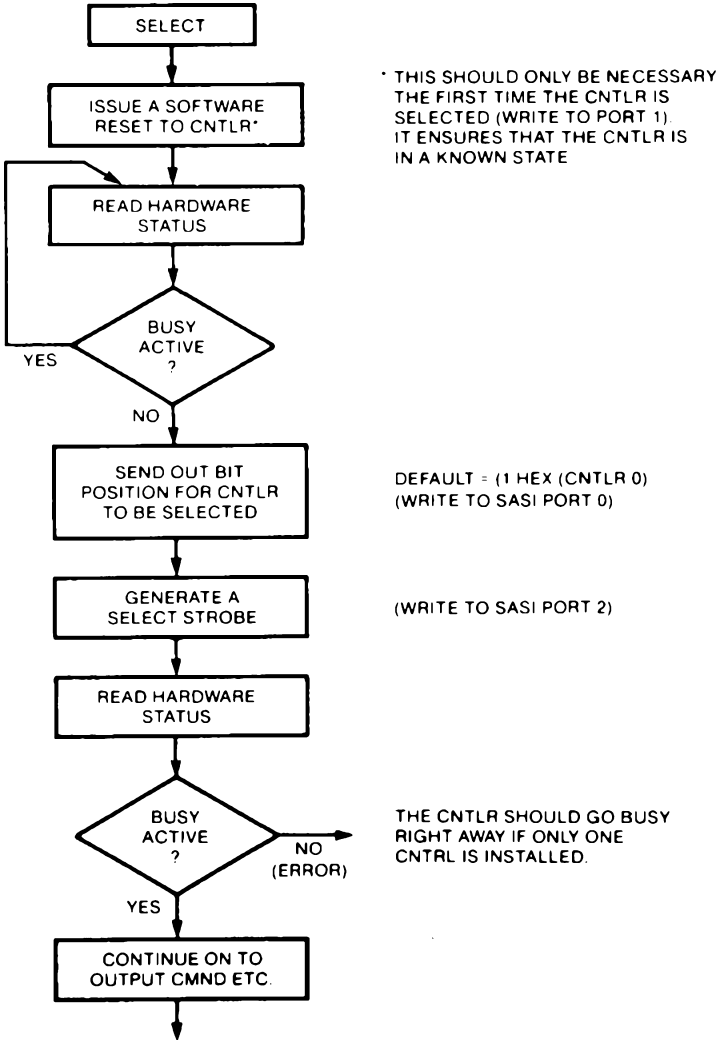

NON DATA TRANSFER COMMANDS.

The Test for Drive Ready command is shown here as an example of a non data transfer command. Some of the other commands which fall into this category are:

- 1) — Recalibrate
- 2) — Format Disk Drive

- 3) — Check Track Format
- 4) — Seek
- 5) — Various diagnostics

This command selects a specified disk drive and verifies that it is ready. This particular command should be issued initially to make sure all disk drives to be accessed during system operation are operational.

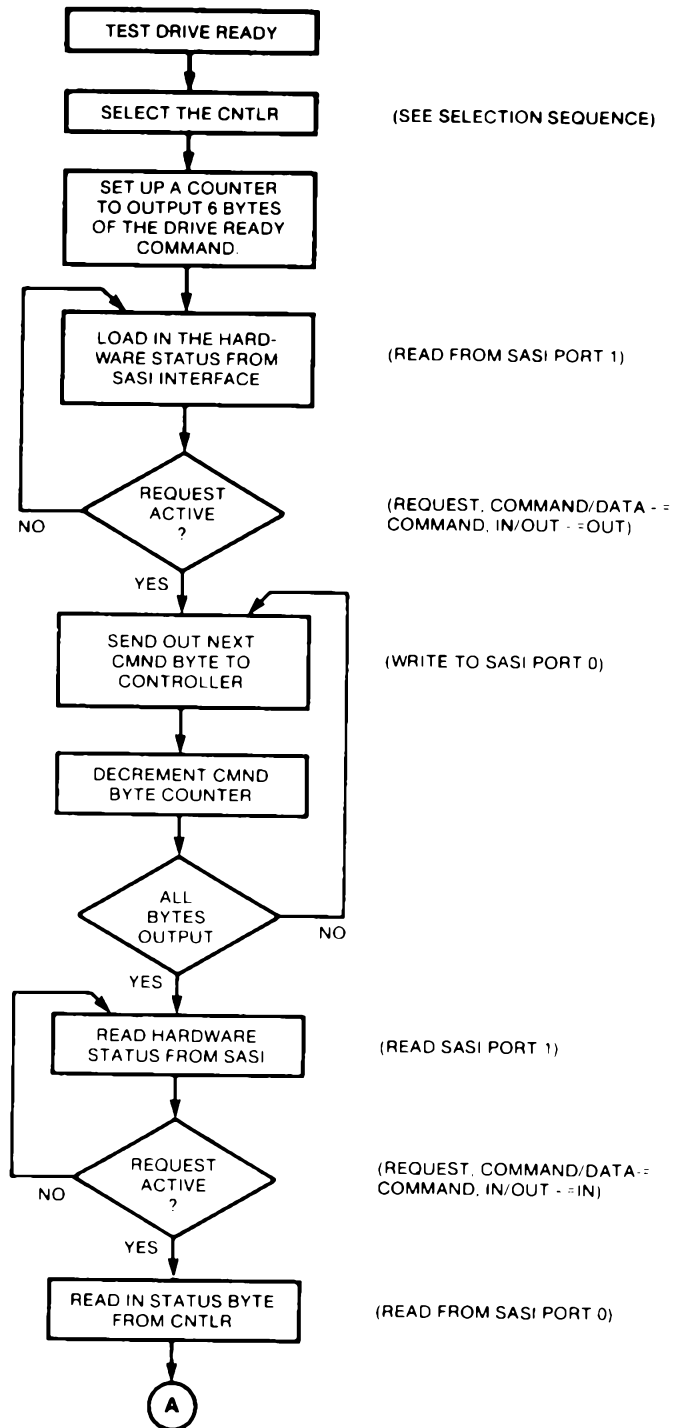

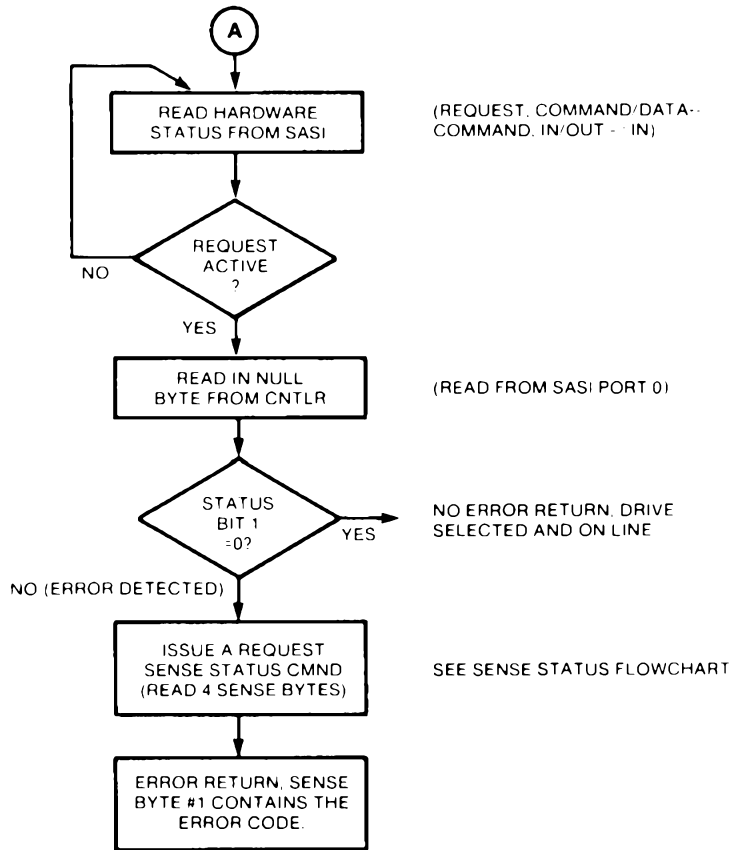

SENSE STATUS COMMAND

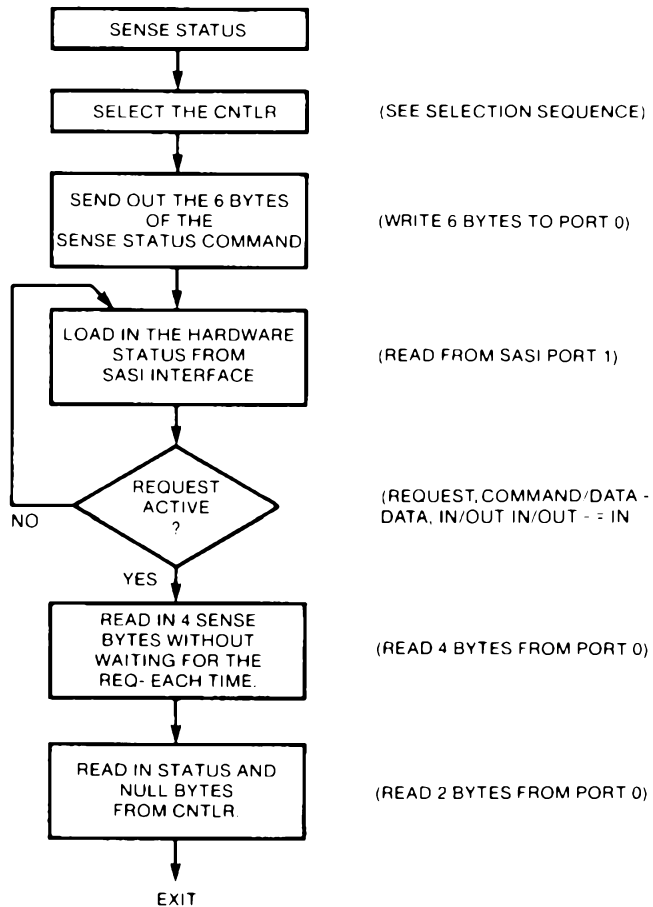

READ USING NON - INTERRUPT I/O

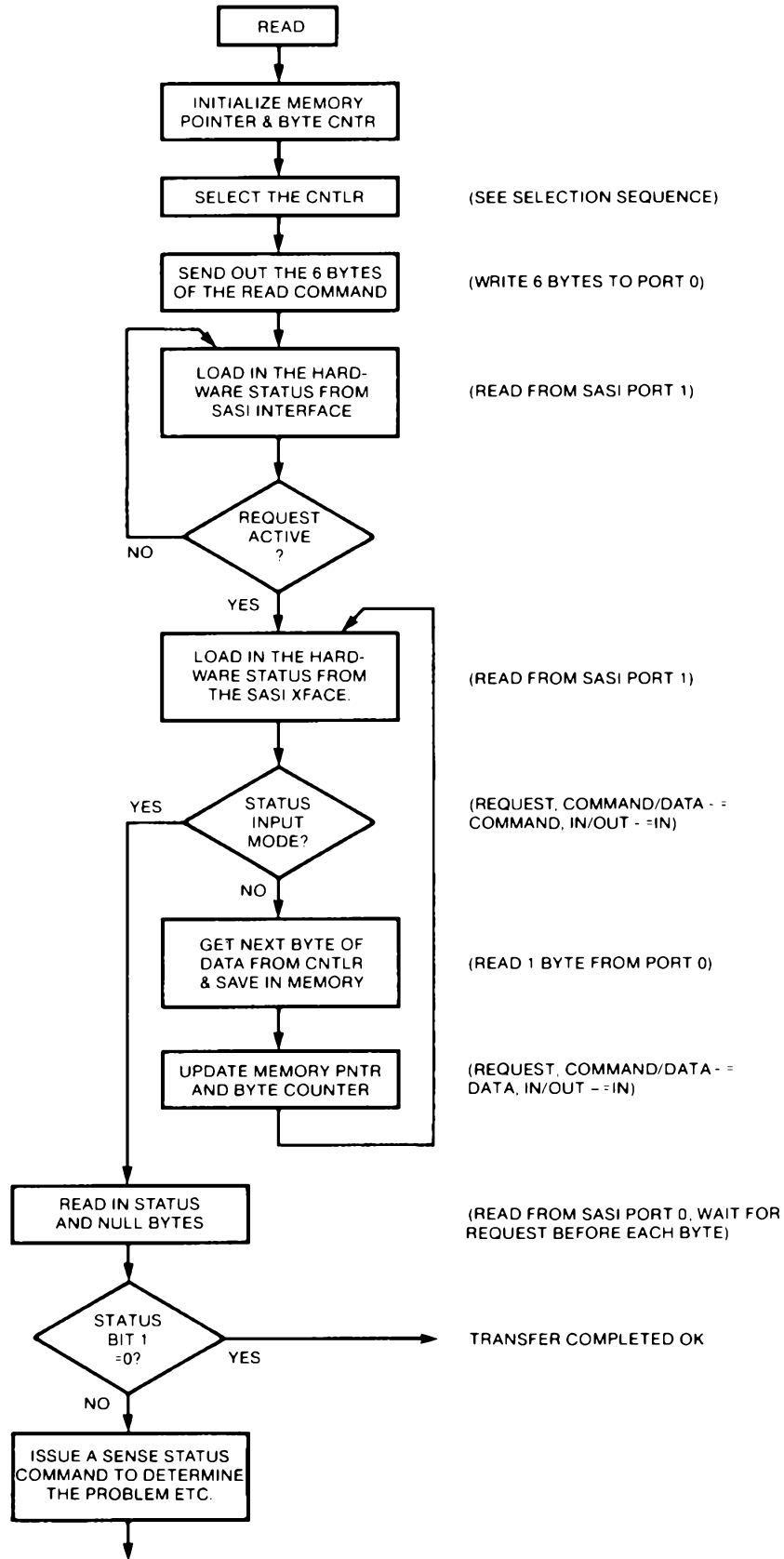

WRITE USING NON- INTERRUPT I/O

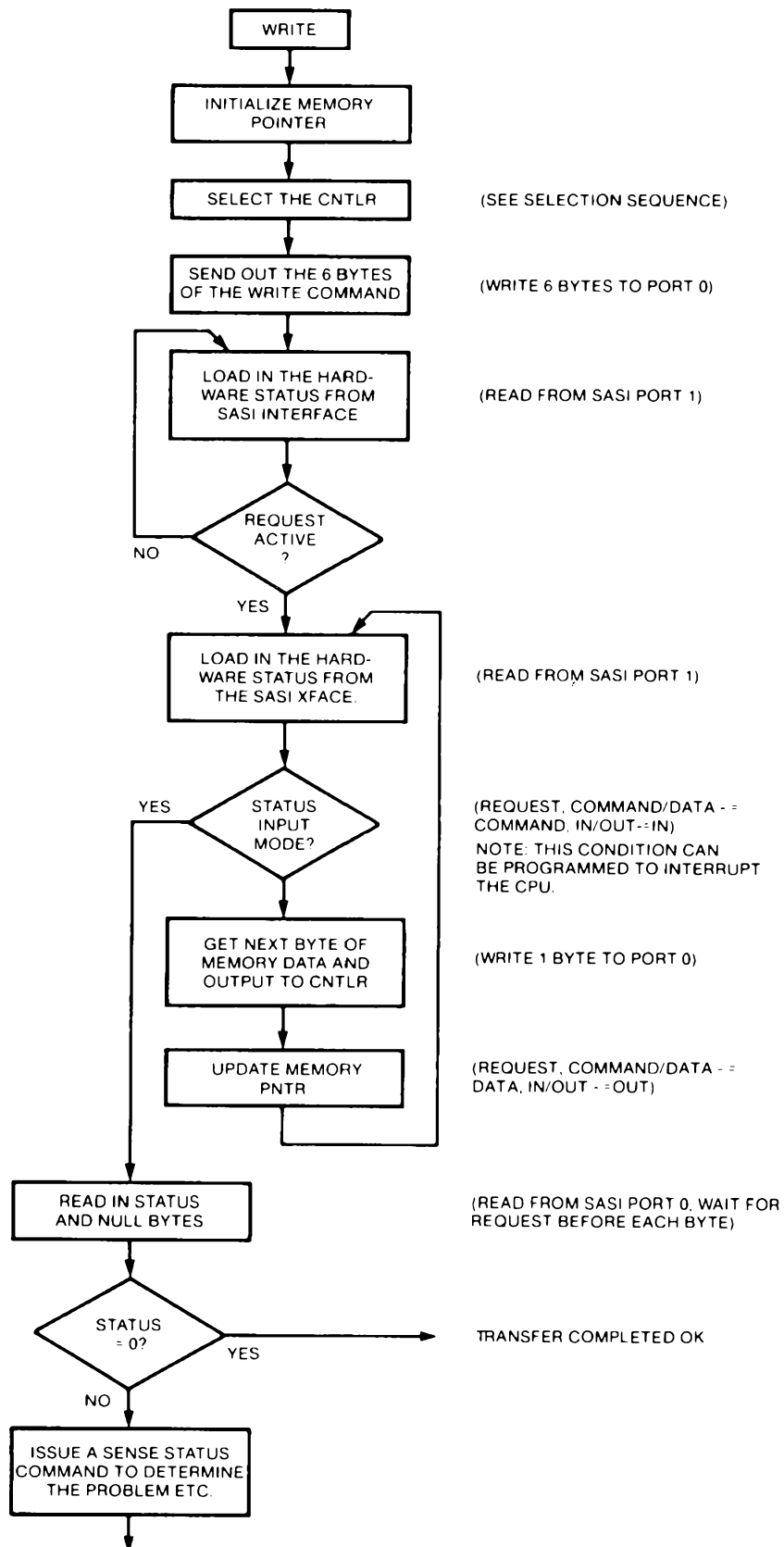

Z80 PROGRAMMING EXAMPLE TO INTERFACE TO THE XEBEC S1410

THIS IS A STAND ALONE PROGRAM WRITTEN IN Z80 ASSEMBLY LANGUAGE WHICH SENDS COMMANDS TO THE XEBEC S1410 CONTROLLER AND 5¼" HARD DISK IN THE FOLLOWING ORDER:

- 1) RESET THE CONTROLLER
- 2) RECALIBRATE THE DRIVE
- 3) FORMAT THE DRIVE
- 4) WRITE ONE SECTOR FROM WRITEBUF
- 5) READ THE SAME SECTOR INTO READBUF

IF THE PROGRAM COMPLETES PROPERLY, THE READ BUFFER (READBUF) AND THE WRITE BUFFER (WRITEBUF) SHOULD BE THE SAME. NORMAL COMPLETION IS AT LABEL TEST6.

LABEL OPCD OPERAND COMMENT

OUTPUT AND INPUT PORTS

WPORT0	EQU	000H	SASI WRITE PORT 0 - WRITE DATA
WPORT1	EQU	001H	SASI WRITE PORT 1 - SOFTWARE RESET
WPORT2	EQU	002H	SASI WRITE PORT 2 - CNTLR SELECT
WPORT3	EQU	003H	SASI WRITE PORT 3 - NOT USED
RPORT0	EQU	000H	SASI READ PORT 0 - READ DATA
RPORT1	EQU	001H	SASI READ PORT 1 - READ STATUS
RPORT2	EQU	002H	SASI READ PORT 2 - NOT USED
RPORT3	EQU	003H	SASI READ PORT 3 - NOT USED

VARIOUS EQUATES

REQBIT	EQU	000H	REQUEST LINE BIT POSITION
REQMASK	EQU	001H	REQUEST MASK FOR BIT TEST
BUSYBIT	EQU	001H	BUSY LINE BIT POSITION
BUSYMASK	EQU	002H	BUSY MASK FOR BIT TEST
MSGBIT	EQU	002H	MESSAGE LINE BIT POSITION
MSGMASK	EQU	004H	MESSAGE MASK FOR BIT TEST
CDBIT	EQU	003H	COMMAND/DATA BIT POSITION
CDMASK	EQU	008H	COMMAND/DATA BIT POSITION TEST
IOBIT	EQU	004H	INPUT/OUTPUT BIT POSITION
IOMASK	EQU	010H	INPUT/OUTPUT BIT MASK

CONTROLLER COMMAND EQUATES

DRVREADY	EQU	000H	TEST DRIVE READY COMMAND
FORMAT	EQU	004H	FORMAT COMMAND CODE
READ	EQU	008H	READ COMMAND CODE
WRITE	EQU	00AH	WRITE COMMAND CODE
SENSE	EQU	003H	STATUS SENSE COMMAND CODE
INITL	EQU	00CH	INITIALIZE DISK SIZE COMMAND
SEEK	EQU	00BH	SEEK COMMAND CODE
RECAL	EQU	001H	RECALIBRATE COMMAND CODE
RAMDIAG	EQU	0E0H	RAM DIAGNOSTIC COMMAND CODE
ERROR	EQU	002H	TEST FOR AN ERROR

<u>LABEL</u>	<u>OPCD</u>	<u>OPERAND</u>	<u>COMMENT</u>
WRITEBUF	DS	256	WRITE BUFFER
READBUF	DS	256	READ BUFFER
STACK	DS	020H	CALL STACK
STACKTOP	EQU	\$	TOP OF STACK
TASK	DB	0,0,0,0,1,80,F,0,0,0,0	

RESET

FIRST RESET THE CONTROLLER

OUT (WPORT1),A SEND OUT A RESET PULSE

TEST FOR DRIVE READY

TEST TO SEE THAT THE DRIVE IS UP AND READY AFTER CONTROLLER HAS BEEN SELECTED.

TEST1	EQU	\$	
	LD	SP, STACKTOP	SET THE STACK POINTER
	CALL	SELCNTLR	SELECT THE CONTROLLER
	LD	A, DRVREADY	DRIVE READY COMMAND
	CALL	TASKOUT	SEND OUT THE COMMAND
	CALL	GETSTAT	GET THE COMPLETION STATUS
	JP	Z, TEST2	TEST FOR PROPER COMPLETION
	RST	038H	ERROR COMPLETION

RECALIBRATE

SEND OUT A RECALIBRATE TO THE CONTROLLER

TEST2	EQU	\$	
	CALL	SELCNTLR	SELECT THE CONTROLLER
	LD	A, RECAL	RECALIBRATE COMMAND CODE
	CALL	TASKOUT	SEND COMMAND TO CNTLR
	CALL	GETSTAT	GET COMPLETION STATUS
	JP	Z, TEST3	TEST FOR ERROR COMPLETION
	RST	038H	ERROR ON COMPLETION

FORMAT

SEND A FORMAT COMMAND TO THE CONTROLLER

TEST3	EQU	\$	
	CALL	SELCNTLR	SELECT THE CONTROLLER
	LD	A, FORMAT	FORMAT COMMAND CODE
	CALL	TASKOUT	SEND COMMAND TO CONTROLLER
	CALL	GETSTAT	GET COMPLETION STATUS
	JP	Z, TEST4	TEST COMPLETION STATUS
	RST	038H	NON ZERO IS AN ERROR

<u>LABEL</u>	<u>OPCD</u>	<u>OPERAND</u>	<u>COMMENT</u>
WRITE			
WRITE OUT A SECTOR TO THE DISK			
TEST4	EQU	\$	
	CALL	SELCNTLR	SELECT THE CONTROLLER
	LD	A,WRITE	WRITE COMMAND CODE
	CALL	TASKOUT	SEND TASK TO CONTROLLER
	LD	HL,WRITEBUF	POINT TO THE WRITE BUFFER
	CALL	REQWAIT	WAIT FOR CNTLR REQUEST
WRITE1	EQU	\$	
	IN	A,(RPORT1)	GET CNTLR STATUS LINES
	AND	CDMASK	TEST FOR COMMAND MODE
	JP	NZ,WRITE2	IF CMND, TRANSFER IS DONE
	LD	A,(HL)	GET A DATA BYTE
	OUT	(WPORT0),A	SEND DATA TO CONTROLLER
	INC	HL	BUMP THE BUFFER POINTER
	JP	WRITE1	MORE TO GO, LOOP
WRITE2	EQU	\$	
	CALL	GETSTAT	GET TRANSFER STATUS
	JP	Z,TEST5	TEST COMPLETION STATUS
	RST	038H	IF STATUS # 0, ERROR
READ			
READ A SECTOR FROM THE DISK			
TEST5	EQU	\$	
	CALL	SELCNTLR	SELECT THE CONTROLLER
	LD	A,READ	READ COMMAND CODE
	CALL	TASKOUT	SEND COMMAND TO CONTROLLER
	LD	HL,READ BUF	POINT TO READ BUFFER
	CALL	REQWAIT	WAIT FOR REQUEST FROM CNTLR
READ1	EQU	\$	
	IN	A,(RPORT1)	GET CNTLR STATUS LINES
	AND	CDMASK	TEST FOR CMND MODE FROM CNTLR
	JP	NZ,READ2	IF ON, END OF TRANSFER
	IN	A,(RPORT0)	READ IN THE DISK DATA
	LD	(HL),A	SAVE IT IN THE BUFFER
	INC	HL	BUMP THE BUFFER POINTER
	JP	READ1	LOOP UNTIL 256 TRANSFERRED
READ2	EQU	\$	
	CALL	GETSTAT	GET COMPLETION STATUS
	JP	Z,TEST6	CONTINUE IF NO ERROR
	RST	038H	ERROR, STOP
TEST6	EQU	\$	
	RST	038H	

<u>LABEL</u>	<u>OPCD</u>	<u>OPERAND</u>	<u>COMMENT</u>
--------------	-------------	----------------	----------------

SELCNTLR

THIS SUBROUTINE SELECTS THE DEFAULT CONTROLLER

SELCNTLR	EQU	\$	
	IN	A,(RPORT1)	READ STATUS PORT
	AND	BUSYMASK	MASK BUSY BIT
	JP	NZ,SELCNTLR	JUMP, IF BUSY
	LD	A,1	CNTLR DEFAULT SELECT CODE
	OUT	(WPORT0),A	SEND IT TO TRANSPARENT LATCH
	OUT	(WPORT2),A	GENERATE A SELECT STROBE
SEL1	EQU	\$	
	IN	A,(RPORT1)	GET CNTLR RESPONSE
	AND	BUSYMASK	ISOLATE THE BUSY MASK
	JP	Z,SEL1	WAIT FOR CNTLR BUSY
	RET		BUSY HAS ARRIVED, EXIT

TASKOUT

THIS SUBROUTINE SENDS OUT THE COMMAND CONTAINED IN A REGISTER TO THE DISK CONTROLLER.

TASKOUT	EQU	\$	
	LD	HL, TASK	POINT TO TASK CONTROL BLOCK
	LD	(HL),A	SAVE THE COMMAND
	LD	B,6	SET UP A BYTE COUNTER
	CALL	REQWAIT	WAIT FOR CONTROLLER REQUEST
TASK1	EQU	\$	
	LD	A,(HL)	GET A COMMAND BYTE
	OUT	(WPORT0),A	SEND IT TO THE CONTROLLER
	INC	HL	BUMP THE TASK POINTER
	DEC	B	DECREMENT THE BYTE COUNT
	JP	NZ,TASK1	WAIT UNTIL ALL ARE OUTPUT
	RET		

GETSTAT

THIS SUBROUTINE RETRIEVES THE STATUS BYTE AND THE NULL BYTE FROM THE DISK CONTROLLER AT THE END OF A COMMAND. THE A REGISTER IS RETURNED WITH A NON-ZERO VALUE IF ERROR HAS BEEN DETECTED.

GETSTAT	EQU	\$	
	CALL	REQWAIT	WAIT FOR REQUEST
	IN	A,(RPORT0)	READ IN THE STATUS BYTE
	LD	D,A	SAVE STATUS TEMPORARILY
	CALL	REQWAIT	WAIT FOR SECOND BYTE
	IN	A,(RPORT0)	GET THE NULL BYTE
	LD	A,D	RESTORE STATUS TO A
	AND	ERROR	ISOLATE THE ERROR BIT
	RET		

LABEL OPCD OPERAND COMMENT

REQWAIT

THIS SUBROUTINE WAITS FOR THE REQUEST LINE TO BECOME ACTIVE FROM THE DISK CONTROLLER.

REQWAIT	EQU	\$	
	IN	A,(RPORT1)	GET CNTLR STATUS BITS
	AND	REQMASK	ISOLATE THE CONTROLLER
	JP	Z,REQWAIT	REQUEST AND WAIT FOR IT
	RET		
	END		

**XEBEC S1410
OWNER'S MANUAL
SUPPLEMENT**

AUGUST, 1982

ADDENDUM A S1410 REV E FIRMWARE

There are major changes on the S1410 Rev E firmware from Rev. D. All changes are downward compatible with software for Rev. D.

A. NEW COMMANDS ADDED

1. Format Alternate Track (OPCODE 'OE' Hex)

Format Alternate Track will format the header fields of the "Bad Track" with the alternate track information (assigned by the host). The alternate track is formatted to identify it as an alternate. The command bytes for Format Alternate Track are:

	7	6	5	4	3	2	1	0
Byte 0	0	0	0	0	1	1	1	0
Byte 1	0	d	d	LOGICAL ADDRESS HI				
Byte 2	LOGICAL ADDRESS MIDDLE							
Byte 3	LOGICAL ADDRESS LO							
Byte 4	0	0	0	INTERLEAVE				
Byte 5	r	r	F	0	s	s	s	s

d = drive, 0 or 1 s = step option, r = retries.

The logical address in the command bytes point to the "Bad Track". Sector address is ignored, defaulting to sector 0.

The interleave byte (4) is programmed the same as in the format command, and is used on the alternate track.

If Bit 5 of Control Byte (5) is set, the data in the existing sector buffer is used to fill the data field. If not set, the data field is written with hex 6C.

After issuing the command the controller will ask for 3 bytes. These bytes point to the host assigned alternate logical address. Again sector address is ignored.

	7	6	5	4	3	2	1	0
Byte 0	0	0	0	LOGICAL ADDR HI				
Byte 1	LOGICAL ADDRESS MIDDLE							
Byte 2	LOGICAL ADDRESS LO							

After receiving the command and the assigned alternate, the controller does the following:

- a) Seeks to "Alternate Assigned Track" and verifies it is not already an assigned alternate track, or flagged bad track.
 - If the track has already been assigned as an alternate or is flagged "BAD", then error code ID Hex is given, and the command is aborted. This usually implies that the host is attempting to assign two (2) bad tracks to the same alternate track.
- b) Formats the track as an assigned alternate track.
- c) Seeks to the "Bad Track" and formats the header as a spare track pointing to the assigned alternate.

NOTE: Data fields on both the bad track and alternate track are destroyed.

Using the Format Alternate Track Command

- a) The controller must be initialized to include the alternate tracks cylinder and head ranges.
- b) With alternate tracks, the entire disk is not available to the system. Generally the disk space is fixed in the system software, which leaves spare tracks at the inner cylinder of the disk, which can be assigned as alternates when needed.
The number of spare tracks is dependent on drive size and number of defects allowed by the drive manufacturer. Generally this is 1 spare track for each 50 to 100 tracks.
- c) Procedure for use is:
 - 1) Format entire disk, including spare tracks.
 - 2) Verify disk.
 - 3) For each media defect, assign an alternate track.
 - 4) Alternate tracks should also be assigned for drive manufacturer list of defects.
- d) In system operation, the alternate tracks are invisible to the host. The controller will automatically seek to the assigned alternate track when an access is made to a flagged defective track. "Consecutive" accesses to a flag track does not result in reseeking to the alternate track. The controller will maintain position on the alternate track.
- e) Direct access (seeking to, or attempted data transfer) to an alternate track results in an error code 'IC' Hex, and no data transfer takes place.

2. Write Sector Buffer (OPCODE 'OF' Hex)

Used to fill the sector buffer with a host given data pattern. No transfer of data takes place between the drive and the controller.

	7	6	5	4	3	2	1	0
Byte 0	0	0	0	0	1	1	1	1
Byte 1	/	/	/	/	/	/	/	/
Byte 2	/	/	/	/	/	/	/	/
Byte 3	/	/	/	/	/	/	/	/
Byte 4	/	/	/	/	/	/	/	/
Byte 5	/	/	/	/	/	/	/	/

This command accepts 256 or 512 bytes (depending on sector size jumper) of data, and stores it in the sector buffer.

3. Read Sector Buffer (OPCODE '10' Hex)

This command sends 256 or 512 bytes of data (depending on sector size jumper) to the host from the sector buffer.

	7	6	5	4	3	2	1	0
Byte 0	0	0	0	1	0	0	0	0
Byte 1	/	/	/	/	/	/	/	/
Byte 2	/	/	/	/	/	/	/	/
Byte 3	/	/	/	/	/	/	/	/
Byte 4	/	/	/	/	/	/	/	/
Byte 5	/	/	/	/	/	/	/	/

B. CHANGES TO FORMAT DRIVE COMMAND

If Bit 5 of control byte 5 of the command block is set on the format command (OPCODE 04), the sector buffer will be used as the data pattern written on the disk data fields.

The Write Sector Buffer command can be issued before the format command to initialize the sector buffer.

C. CHANGE TO FORMAT TRACK COMMAND

The Format Track Command will reformat the track, eliminating all references to bad and alternate tracks. Also if Bit 5 of control byte 5 of the command block is set, then the sector buffer will be used as the data pattern in the data field.

D. EXPANDED FAST STEP OPTIONS

The fast seek steps supported have been increased to include many of the popular drives. The new step option selection is downward compatible with previous step options supported.

The step options are encoded in control byte 5 of the command descriptor. The encoding is done with bits 0 thru 3 as follows:

<u>DESCRIPTION</u>	<u>BITS</u>			
	3	2	1	0
Default 3 msec step rate	0	0	0	0
Seagate ST506 (MLC2)	0	0	0	1
Tandon fast step	0	0	1	0
Texas Instrument fast step	0	0	1	1
200 usec buffered step	0	1	0	0
70 usec buffered step	0	1	0	1
30 usec buffered step	0	1	1	0
15 usec buffered step	0	1	1	1
Olivetti 2msec/step (561)	1	0	0	0
Olivetti (562) fast step (1.1 msec typical)	1	0	0	1
Spare (for future use)	1	0	1	1 thru
	1	1	1	1

Refer to the drive manufacturer manual in configuring the drive for fast, or buffer step options. In cases where the drive is hardware configured for fast step, all commands which require seek option selection must use the fast step option for that drive.

E. DESCRIPTION OF OVERLAP SEEKS WITH BUFFERED STEP DRIVES

For drives employing buffered seeks, seek commands can be overlapped. After the controller issues a seek to the drive, it returns with a completion status, not waiting for the drive to complete the seek. If the return status shows no error, then the seek was issued correctly. If there is an error, then the seek was not issued. After transferring the status, another command can be issued to either drive. If a new command is received for a drive with an outstanding seek, then the controller will wait, with Busy active, for the seek to complete before executing the new command (Except Test Drive Ready Command). There is no timeout condition in the controller, waiting for the buffered step seeks to complete.

The Test Drive Ready command can be used with overlapped seeks to determine when a drive has completed seeking before issuing the next command. If the drive is still seeking, the status byte at the end of the command will indicate an error, and the sense status will indicate "drive still seeking" (type 0 error, code 8). A sequence of Test Drive Ready commands can thus be used to determine when the drive is ready for the next command.

F. NEW ERROR CODES

NOTE: The address Valid Bit (bit 7) may or may not be set, and is not included here for clarity.

Error Code (Hex)	Description
IC	Illegal (direct) access to an alternate track.
ID	On a format alternate track command, the requested alternate track has already been assigned as an alternate, or is flagged as a bad track.

- IE When the controller attempted to access an alternate track from a spared track, the alternate track was not flagged as an alternate.
- IF On a format alternate track command, the bad track equalled the alternate track.

TIMING CLARIFICATIONS

A. CONTROLLER SELECTION

The SELECTION signal should NEVER be activated (SEL - =0) within 1 microsecond of the deactivation of the BUSY signal (BUSY - =1) or within 10 microseconds after a RESET; if this timing is violated, the controller may not be able to accept the selection sequence.

B. OTHER TIMING CONSIDERATIONS

<u>FROM</u>	<u>TO</u>	<u>TIME</u>
SEL	REQ	100 microseconds
RESET OR POWER ON	CONTROLLER READY	2 milliseconds
WRITE COMMAND	1ST DATA REQUEST	200 microseconds
MESSAGE BYTE	END OF BUSY	10 microseconds

ADDENDUM B

A. CONTROLLER RETRY ALGORITHMS

When any error is encountered, except an ECC error in the data field, the S1410 Controller examines Bit 7 of the Control Byte (Byte 5) to determine the retry method to use.

If Bit 7 is set, the Controller will not retry the operation, but reports the error immediately. If Bit 7 is reset, the Controller will retry the operation 3 times, then recalibrate the drive, seek back to the current track, and retry once more. For example, if an ADDRESS MARK (AM) NOT FOUND error occurs, the Controller attempts to reread the same sector 3 times. If the error persists, the Controller recalibrates the drive to track 0, seeks to the target track and rereads for the last time. If the error still persists, the Controller aborts the command and reports the error to the host.

If Bit 6 is set, the Controller will not retry a read of a sector that contains a data error before attempting error correction. If Bit 6 is reset, the Controller will reread the sector before attempting error correction. It is faster and more reliable to read the data again than apply error correction immediately. If the data error is transient in nature, such as noise or electrical interference in the disk heads or read amplifier, noise in cable, or a power supply transient, then another read of the sector will be successful. If the error occurs twice in succession, the error is caused by a media defect, so ECC correction is used to recover the data.

B. FORMAT SECTOR INTERLEAVE

The S1410 controller will accept any interleave value between zero and the number of sectors per track minus one. The interleave value tells the Controller where the next logical sector is located in relation to the current sector. For example, an interleave value of one specifies that the next logical sector is physically the next sector on the track. An interleave of two specifies that the next logical sector is two sectors ahead of the current sector, so there is one sector between each logical sector. An interleave of three specifies that the next logical sector is three sectors ahead, so there are two sectors between each logical sector. Thus, the number of physical sectors between any two adjacent logical sectors is the interleave value minus one. An interleave of zero will be converted to interleave of 1 automatically. Any out of range interleave value will result in an Invalid Command Error.

The interleave value can be set to improve system throughput based on overhead time of the host software, overhead time in the disk driver, and overhead time for the S1410 controller to process a command. If the host system is capable of multisector transfers, system throughput can be optimized by setting the interleave value such that the next logical sector comes under the the heads just as the S1410 completes the data transfer of the previous sector. If the host is capable of passing a sector of data at DMA speed (one millisecond for a 256 byte sector), then the interleave value should be set to four to optimize multisector transfers. This is the minimum value for continuous sector transfers. If a sector data transfer takes between one and two milliseconds, set the interleave value to five. The best method is to experimentally determine the best interleave value for your system using a representative benchmark.

C. EXPANDED COMMAND CODE EXPLANATION

1. Test Drive Ready (Class 0, Opcode 00)

This command selects the drive specified by the Byte 1 of DCB and read back the status from that drive. If all status bits are in the correct state, the command will not return an error code. If the drive status is not OK, the command will return an error code, usually DRIVE NOT READY, or DRIVE STILL SEEKING.

This command is usually used in 2 occasions:

- a) When initially power on, the host should issue this command continuously with appropriate time out loop to insure the drive spins up to speed and comes ready.
- b) When implementing overlapped seeks. First, issue a seek command to the 1st drive, then issue another seek command to the 2nd drive. Now keep issuing a TEST DRIVE READY command to each drive until either drive finishes its seek operation. Then continue with the normal READ/WRITE operation on that drive.

2. Recalibrate (Class 0, Opcode 01)

This command will move the drive arm to the track 00 position. This command should only be used to attempt to correct a drive position error, since it is slower than a direct seek to track 0. Also, if retries are enabled, the Controller will recalibrate automatically in case of error. The difference between this command and a direct seek to track 0 is this command steps the drive one cylinder at a time looking for the signal TRACK00 from the drive to become active. A direct seek to track 0 is faster because the Controller steps the drive at the programmed step rate.

3. Request Sense Status (Class 0, Opcode 03)

This command must be executed immediately following a command in which the error bit is set in the completion status byte in order to determine the error code. This is necessary because the error code will be cleared when the Controller executes next command. (Refer to Owner's Manual page 21 for more detail)

4. Format Drive (Class 0, Opcode 04)

This command recalibrates the drive, then seeks to the starting address specified by the byte 1, 2 and 3 of the DCB. It times the spindle speed, divides the track into equal size sectors, and writes out address mark (AM) and header field for all sectors. The logical sector layout is specified by the interleave value contained in byte 4 of the DCB. Then it reads back the AM and header field and writes the DATA field for all sectors. The data pattern is defaulted to 6C Hex or the host can initialize the pattern by using OPCODE 0F Hex (WRITE SECTOR BUFFER) and then set bit 5 of the Control Byte of the DCB to 1 in the FORMAT DRIVE command to tell the controller not to change the buffer contents. Note that if the format command gets a hard error while formatting a track, the format operation stops immediately and the error is reported. To continue, the host software must provide the data fields for all logical sectors following the sector in error, then

continue with the format command at the beginning of the next track. Also note that the format operation always starts at the first sector of a track, even though the address specified in the DCB did not point to a track boundary.

5. Check Track Format (Class 0, Opcode 05)

This command will generate an interleave table from the byte 4 of the DCB, seek to the target track (without recalibrating), and read each sector from sector 0 to the last sector. While reading each sector, the Controller checks for a bad ID field with the value generated in the interleave table. If a discrepancy occurs between the sector number read and the value in the interleave table, the controller will report the error code 0A hex, wrong interleave. The Controller does not read the DATA field in this command.

6. Format Track (Class 0, Opcode 06)

This command recalibrates the drive, seeks to the target track specified in byte 1, 2 and 3 of the DCB, and writes the ID and DATA fields with the interleave value specified in byte 4 of the DCB. This command can be used to clear the defective or alternate track bits, or to reformat one track that lacks data integrity on a drive.

7. Format Bad Track (Class 0, Opcode 07)

This command is the same as FORMAT TRACK command except the BAD TRACK flag is set in the ID field. DATA fields are not written. This command is used to prevent system access to defective tracks. There is an alternate way to process bad tracks. See OP CODE 0E Hex ASSIGN ALTERNATE TRACK for details.

8. Read (Class 0, Opcode 08)

This command will read 1 to 256 sectors as specified by the byte 4 of the DCB. The starting address is specified by byte 1, 2 and 3 of the DCB. The address specified by the address field is the linear sector number from the beginning of the disk. The first sector of the disk is sector zero. The Controller converts this linear address to the physical cylinder, head, and sector address for the drive. If an error occurs during a multiple sector transfer, the transfer will terminate at the sector where the error occurs. For example, assume the user wants to read 10 sectors starting at logical address 1000. If a correctable data error occurs at logical address 1005, the Controller completes the transfer of 6 sectors, including the sixth one because the data was corrected. It terminates the read operation and sets the completion status byte error bit high. The host issues REQUEST SENSE Command to determine what error has occurred. To continue the operation, the host calculates the difference between sectors desired and sectors completed. In this case, 6 out of 10 are completed, therefore, the host should issue a second read command of 4 remaining sectors at starting logical address 1006. If any other error code occurred, the data is not returned to the host, so the retry logical address is one sector less, and the retry sector count one sector more than the continuation after a correctable data error. In the previous example, the restart logical address is 1005, and the transfer length is 5 sectors for any error other than a correctable data error.

9. Write (Class 0, Opcode 0A)

This command will write from 1 to 256 sectors as specified by the byte 4 of the DCB, starting at the address specified by bytes 1, 2 and 3 of the DCB. The multiple sector transfer scheme works the same as the READ command.

10. Seek (Class 0, Opcode 0b)

This command is used to seek to the target address as specified by byte 1, 2 and 3 of the DCB. Byte 5 of the DCB of this command instructs the Controller what type of seek algorithm to execute for this drive. There are currently 10 different seek types supported in REV F, both buffered and non-buffered modes. Buffered Step Drives are supported at 15, 30, 70, or 200 microseconds per step. Buffer step means the drive has seek intelligence built-in. It can accept step pulses at a fast rate, typically under 200 microseconds per step. After the Controller stops sending the drive step pulses (i.e. the Drive doesn't receive any more pulses within its timeout limit), the Drive seeks based on its own stepping algorithm (typically from firmware built-in to the drive). This scheme allows the Controller to finish the command without having to process the physical seek operation, making overlapped seeks possible. There are 2 more fixed step rates, 2 and 3 milliseconds per step. The other 4 step rates are custom fast step rates for Seagate, Texas Instrument, Tandon and Olivetti drives. Please see S1410 OWNER'S MANUAL Supplement (REV. E-4) for more details.

11. Initialize Drive Characteristics (Class 0, Opcode 0C)

This command is fully described in the S1410 OWNER'S MANUAL page 27. If the drive and controller are powered from a different power supply than the host system, the software driver should issue this command before each seek or data transfer operation. This prevents the Controller from "forgetting" the drive parameters if a power line transient resets the controller, but doesn't reset the host computer. Two different drive types may be supported on the same Controller by always issuing this command for each drive before any seek or data transfer operation.

12. Read ECC Burst Error Length (Class 0, Opcode 0D)

This command is only valid following a Correctable Data Error (Error Code 18 Hex). It will transfer one byte to the host indicating the length of the error corrected. The error length is determined by counting the number of bits between the first and the last bit in error, including the first and the last bits. For example:

Assume the drive is formatted with the default format data pattern 6C Hex. The first 2 bytes expanded to the binary level has the pattern — 0110 1100 0110 1100. This is the 2 byte pattern stored on the disk. Now, if the data read back from the disk has an error, then:

CORRECT PATTERN	:	0110 1100 0110 1100	0
READ BACK PATTERN	:	0111 1100 0110 1100	1
READ BACK PATTERN	:	0111 1100 1110 1100	6
READ BACK PATTERN	:	0111 1100 0110 1110	12

From the 3 pattern read above, the first and second patterns are correctable because the error bit span is less than or equal to 11 bits. The third pattern is uncorrectable since it exceeds the Controller's Correction capability, which is 11 bits.

13.Format Alternate Track (Class 0, Opcode 0E)

This command is fully described in the S1410 OWNER'S MANUAL Rev. E-1 (in the S1410 OWNER'S MANUAL Supplement)

14.Write Sector Buffer (Class 0, Opcode 0F)

This command is usually used in 2 ways:

- a) Write a test pattern to the Controller and read it back to verify the Controller's buffer memory is functioning.
- b) If the user wants another data field pattern for format such as E5 Hex for CP/M compatibility, the user can initialize the data pattern by writing the data pattern to the Controller. Then, before issuing the FORMAT DRIVE or FORMAT TRACK command, set byte 5 of the DCB high to tell the Controller to use the data pattern in the buffer instead of the default format data pattern.

15.Read Sector Buffer (Class 0, Opcode 10)

This command is also usually used in 2 ways:

- a) Read the contents of the data buffer after writing it using WRITE SECTOR BUFFER command to test the RAM.
- b) If an uncorrectable data error occurs, the Controller will not send data to the host, but reports the error immediately. If the host wants to corrupt data, then the host issues this command to retrieve it.

16.Ram Diagnostic (Class 7, Opcode 00)

This command does a walking 1 and walking 0 pattern test of its internal RAM buffer.

17.Drive Diagnostic (Class 7, Opcode 04)

This commands recalibrates the disk drive, then reads sector 0 of each track to verify that both ID and data field are correct.

18.Controller Internal Diagnostic (Class 7, Opcode 04)

This command checksums the EPROM by adding the value of each memory location modulo 256 across the programmed area. The newly calculated checksum is compared to the checksum stored permanently in the EPROM. If the checksums do not compare, then a CHECKSUM ERROR (Error Code 31 Hex) is returned. The data buffer test is the same as RAM DIAGNOSTIC. The ECC circuitry is tested by introducing an artificial error to the data and check that the ECC circuitry detects the error. It also passes a good pattern and sees if the ECC circuitry detects no ECC error.

19. Read Long (Class 7, Opcode 05)

This command is used to test the ECC circuitry. When the host issues a write command to the Controller (assume 256 bytes/sector), the Controller writes to the disk the 256 bytes sent by the host and appends the four bytes generated by the ECC hardware. During a normal read command, the Controller reads the 256 data bytes plus the 4 ECC bytes into the buffer. But the Controller sends only the 256 data bytes to the host. The 4 ECC bytes are used to determine if an ECC data error occurred. The only difference between READ LONG and READ is the Controller appends the 4 ECC bytes to the data transfer, making the sector transfer 260 bytes long. The method to test the ECC circuitry is as follows:

- a) Use the normal READ command to find a sector that does not have any data errors.
- b) Use READ LONG to read that sector plus ECC into the host.
- c) Modify the data pattern in a known way.
- d) Use WRITE LONG to write the pattern to the same sector.
- e) Use the READ command to read the same sector again .
- f) If the pattern change is less than or equal to 11 bits in length, the Controller flags it as a correctable data error. If the change is greater than 11 bits in length, the Controller will flag it as an uncorrectable data error.
- g) Use a WRITE command to restore the sector for system use.

20. Write Long (Class 7, Opcode 06)

When this command is used, the host supplies the 4 bytes of ECC information following the 256 bytes data. This command is used to test the Controller's ECC circuitry only. For detail description of the test, see the READ LONG command above.

D. EXPANDED ERROR CODE EXPLANATION

This section details the S1410 Error Codes returned in the REQUEST SENSE STATUS command. The cause of the error is given, followed by the most probable source of the error. The error codes numbers are given in HEX notation.

- | | |
|----|---|
| 00 | No error occurred. This code is always returned if no error had occurred during the previous command. |
| 01 | No index Signal from the Drive. This error occurs during any data transfer or format command if a normal drive select occurs, the drive is ready, but |

no index signal is detected from the drive within two revolutions of the disk. Possible error causes are:

- Bad Drive
- Control Cable (J1)
- Controller

02 No Seek Complete Signal from the Drive. This error occurs on non-buffered seek processing if the controller does not receive the Seek Complete signal from the Drive within one second following the last step pulse.

Possible error causes are:

- Bad Drive
- Control Cable (J1)
- Controller

03 Write fault Signal Received from the Drive. This error occurs if the controller detects an active write fault signal from the disk drive either at the completion of a sector data transfer or initially after a successful drive select and the drive indicates ready.

Possible error causes:

- Drive Power supply voltages out of range
- Bad Drive
- Control Cable (J1)
- Unit Cable (J2, J3)
- Controller

04 Disk Drive Not Ready. This error occurs if the controller fails to receive the select signal from the drive, or the drive indicates not ready after selection.

Possible error causes:

- Drive Power supply voltages out of range
- Drive not yet up to operating speed following power on
- Bad Drive
- Control Cable (J1)
- Controller

06 Track 00 Not Found. After stepping the drive 200 more steps than the number of cylinders during a recalibrate command, the Track 00 Signal was not received from the drive.

Possible causes are:

- Incorrect Drive Size Initialization (too few cylinders)
- Bad Drive
- Control Cable (J1)
- Bad Controller

08 Disk Drive Still Seeking. This status is returned in response to a test drive ready command if a buffered step seek was issued to a drive and the drive has not returned the seek complete signal. Software must time the seek to insure no system hang occurs if the drive fails to return the seek complete signal. Treat a seek incomplete condition the same as error code 02.

10 ID Field Read Error. During a data transfer or format command, address marks were detected, but the target sector was not found and an ECC error occurred on one or more ID fields.

Possible causes are:

- Media Defect on Drive
- Bad Drive (If errors are excessive or continuous)
- Bad Controller (If errors are excessive or continuous)

Media defects may be overcome by deleting the defective sectors from system use or assigning an alternate track.

11 Uncorrectable Data Error in the Data Field. The controller detected a data error that could not be corrected using ECC. The error span is greater than 11 bits.

Possible causes are:

- Media Defect on Drive
- Bad Drive (If errors are excessive or continuous)
- Bad Controller (If errors are excessive or continuous)

Media defects may be overcome by deleting the defective sectors from system use or assigning an alternate track.

12 Sector Address Mark Not Found. The controller did not detect an address mark (AM) from the

drive within its timing window. An address mark is a special recording pattern preceding the ID field of a sector. The AM is only written at format time. The AM tells the controller where new sector starts. The error may occur during any data transfer or format commands. The error may mean that no address marks were detected on the track, or the target sector address mark was not detected.

Possible causes are:

- Media Defect on Drive
- Drive has not been formatted
- Bad Drive
- Bad Unit Cable (J2, J3)
- Bad Controller

Media defects may be overcome by deleting the defective sectors from system use or assigning an alternate track.

- 14 Target Sector Not Found. The target sector was not located within two revolutions of the disk. This error usually occurs when there is a media defect in the address mark field of the target sector.

Possible causes are:

- Media Defect on Drive
- Invalid Format (Changing sector strap from 512 to 256 bytes and not reformatting the drive).
- Bad Drive
- Bad Controller

- 15 Seek Error. After a seek, the target disk address did not match the ID address read from the disk. Either the cylinder or head bytes did not match.

Possible causes are:

- Incorrect Seek Option Specified in the Command.
- Bad Drive
- Bad Control Cable (J1)
- Bad Controller

- 18 Correctable Data Error. The controller detected a media error while reading that was corrected by ECC. This error code informs the host software that error correction has taken place. This is the only error where the data is passed to the host before returning the error status.

- 19 Track is Flagged Bad. The last data transfer command encountered a track that had been flagged defective using the Format Bad Track command. Host software is responsible for insuring that deleted tracks are never accessed.
- 1A Format Error. During execution of a check track command, the controller detected an unformatted track, the wrong interleave on disk, or an ID ECC error on at least one sector.
- 1C Controller Detected a Direct Access to an Alternate Track. A track that has the alternate track flag set in the ID has been directly accessed by the host, instead of coming from the defective track that is assigned to this alternate track. Care must be used in software to insure that the alternate track area is not accessed during data transfer commands.
- 1D The Designated Alternate Track is already assigned to another Defective Track. Host software has attempted to assign an alternate track to replace a defective track, but the alternate had previously been assigned to a defective track. If an alternate track is no longer needed, the host software must reformat the track using the FORMAT TRACK command before attempting to reassign the track again.
- 1E Assigned Alternate Track Not Found. A defective track has been assigned an alternate track, but the alternate track does not have the alternate track bit set in the ID field. This may be caused by reformatting the alternate track with the format track command without reprocessing the defective track.
- 1F The Alternate and Defective Track Addresses point to the same track. Host software has attempted to assign a defective track to itself. That is not allowed in this alternate track scheme.
- 30 RAM Diagnostic Failure. The controller fails to pass the RAM memory test diagnostic. Replace the controller.
- 31 Program Memory Checksum Error. The controller was unable to obtain a match between the calculated and compare checksum values. This is caused by a defect in the program memory chip of the controller.
- 32 ECC Check Failure. The controller ECC diagnostic failed, replace the controller.

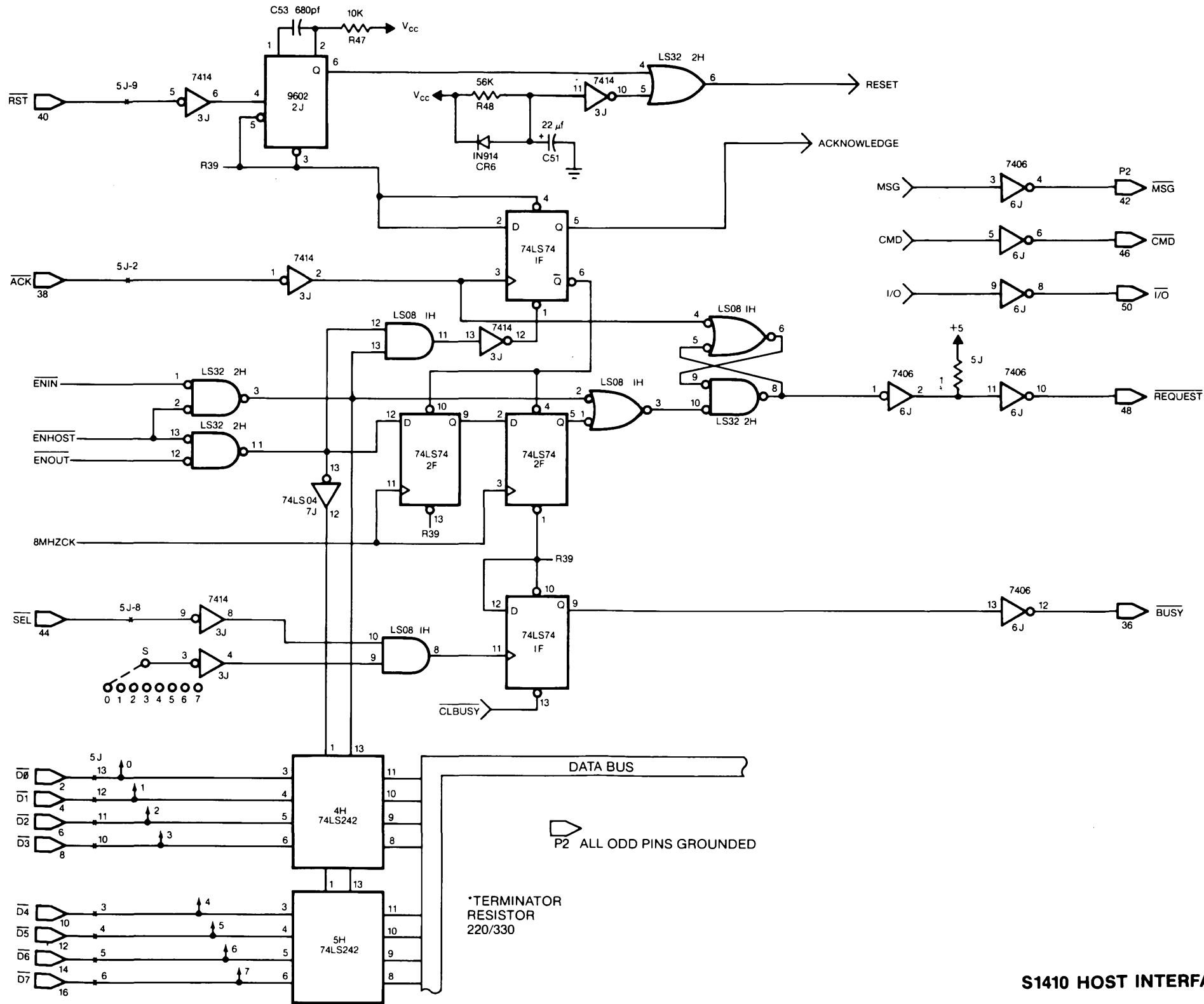

S1410 HOST INTERFACE

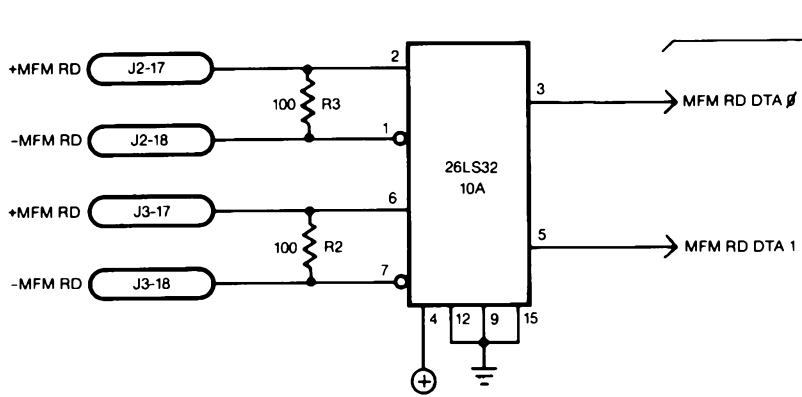

TO S1410

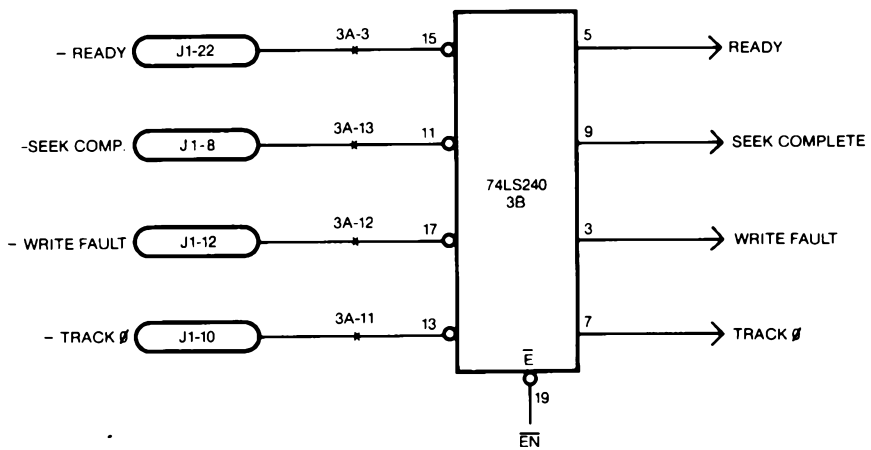
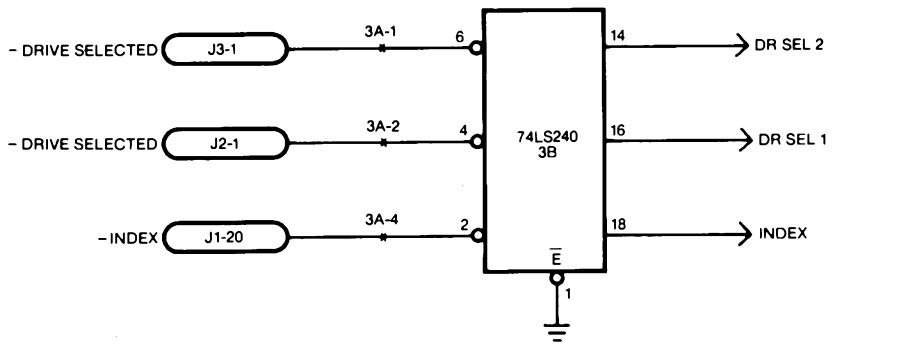
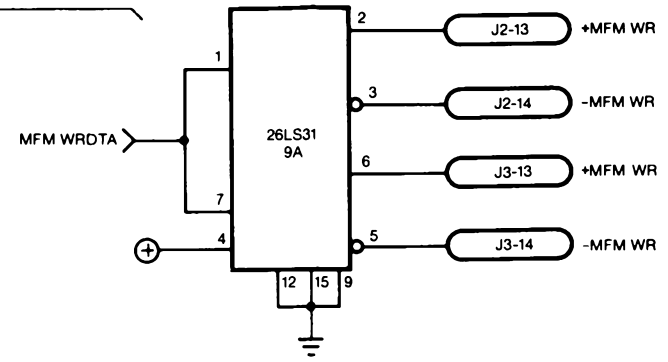

X TERMINATOR RESISTOR 220/330

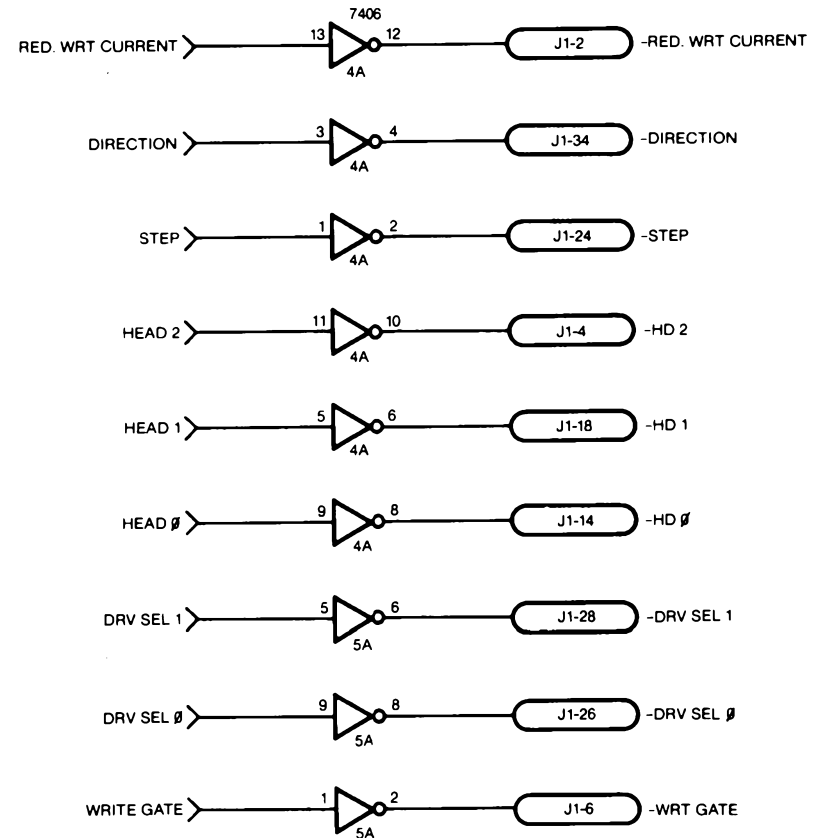

S1410 DRIVE INTERFACE

Z-80 PROCESSOR INTERFACE TO THE XEBEC S1410 CONTROLLER

Z-80 SIGNAL DEFINITIONS

\overline{RD} — μP NEGATIVE TRUE READ SIGNAL

\overline{IO} — DECODED μP NEGATIVE TRUE INPUT/OUTPUT SIGNAL

\overline{S} — DECODED S1410 DEVICE ADDRESS SELECT LINE WITHOUT 2 LSB'S

\overline{WR} — μP NEGATIVE TRUE WRITE SIGNAL

A1 — TWO LEAST SIGNIFICANT POSITIVE

A0 — TRUE μP ADDRESS BITS

