

**ASCII KEYBOARD  
HASCII KEYBOARD  
POWER SUPPLY BOARD  
SYSTEM BOARD**

See Folder CSCS4

**DISK DRIVE**  
See Folder CSCS4-C**MONITOR**  
See Folder CSCS4-D**GMS BOARD**  
See Folder CSCS4-BEPSON  
MODEL QX-10  
**CSCS4-A****CSCS4-A**  
EPSON  
MODEL QX-10**INDEX**

	Page		Page
GridTrace Location Guide .....	15	Photos	
IC Pinouts & Terminal Guides .....	6,11	GGG Board .....	5,7,14
Line Definitions .....	16,17	Schematics .....	2,3
Logic Chart .....	12,13	Schematic Notes .....	4
Miscellaneous Adjustments .....	4	Troubleshooting .....	4
Parts List .....	8,9,10		

**Howard W. Sams & Co., Inc.**

4300 West 62nd Street, P.O. Box 7092, Indianapolis, Indiana 46206 U.S.A.

The listing of any available replacement part herein does not constitute in any case a recommendation, warranty or guaranty by Howard W. Sams & Co., Inc., as to the quality and suitability of such replacement part. The numbers of these parts have been compiled from information furnished to Howard W. Sams & Co., Inc., by the manufacturers of the particular type of replacement part listed.

Reproduction or use, without express permission, of editorial or pictorial content, in any manner, is prohibited. No patent liability is assumed with respect to the use of the information contained herein.

© 1985 Howard W. Sams &amp; Co., Inc.

4300 West 62nd Street, P.O. Box 7092, Indianapolis, Indiana 46206 U.S.A.

Printed in U.S. of America.

**84CS14930****DATE 4-85**



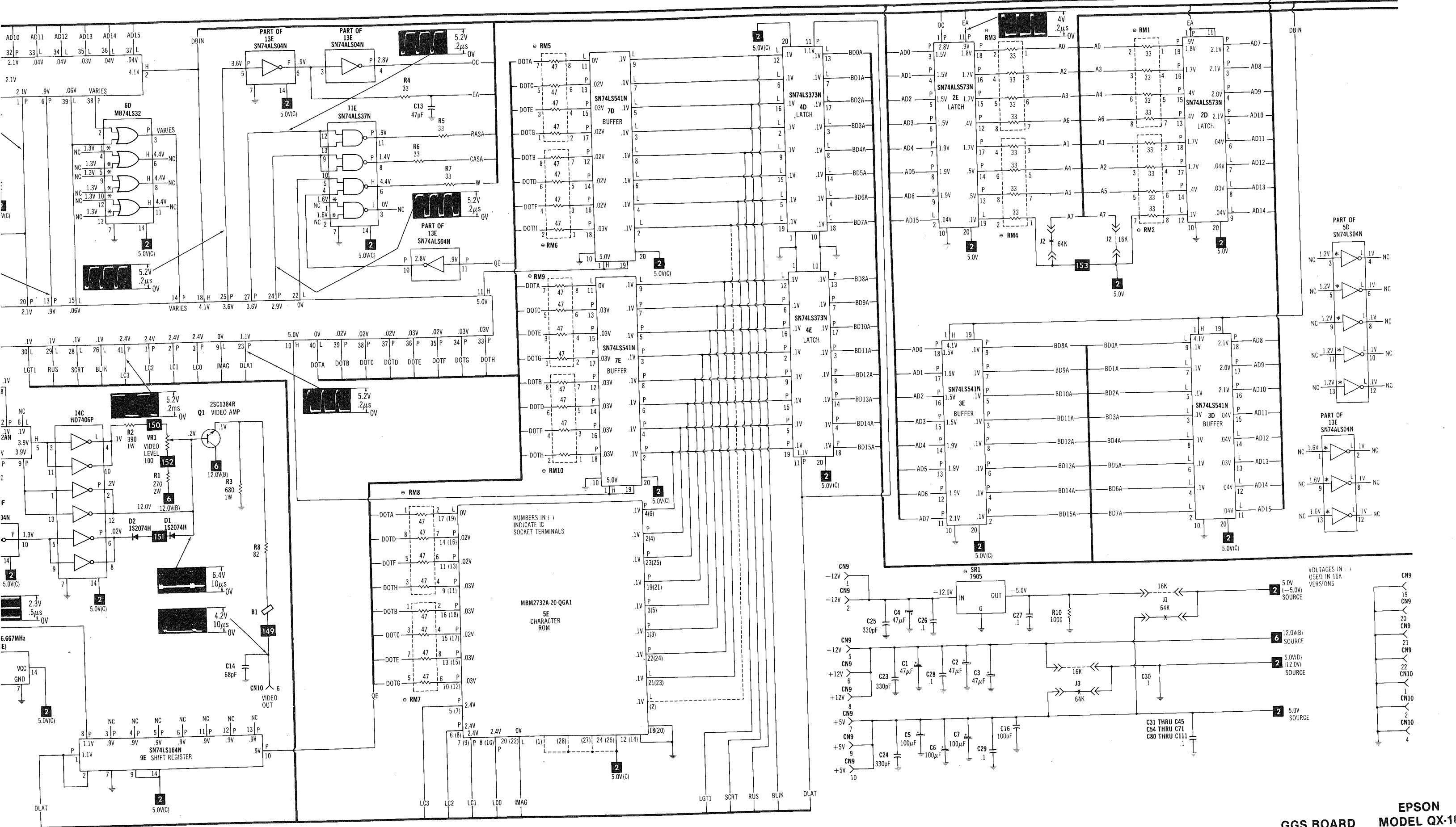

SEE LINE DEFINITIONS ON PAGES 16 AND 17

EPSON  
GGS BOARD  
MODEL QX-10

EPSON  
MODEL QX-10

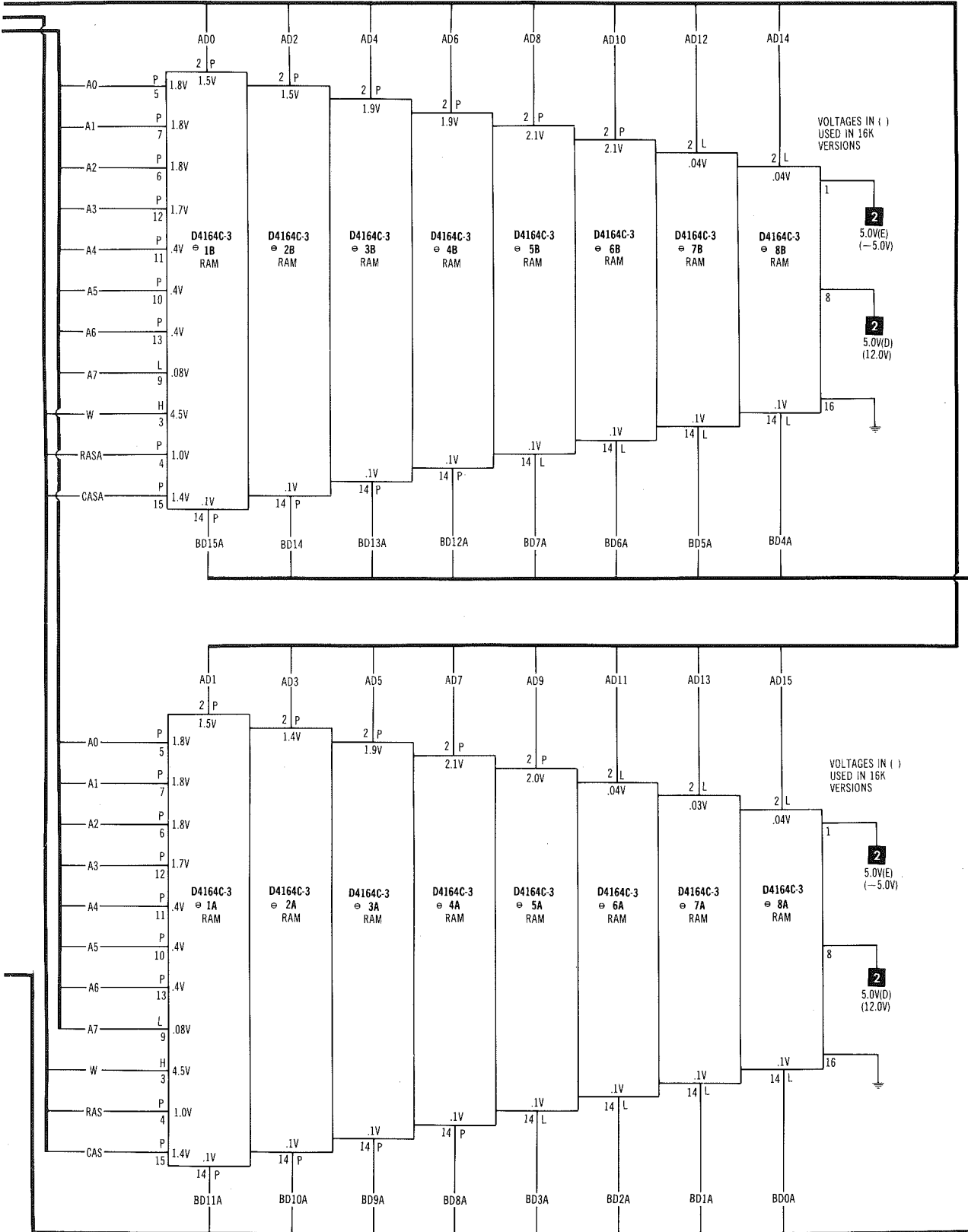

A PHOTOFAC STANDARD NOTATION SCHEMATIC  
WITH **CIRCUITRACE**

© Howard W. Sams & Co., Inc. 1985

**GGs BOARD**

# TROUBLESHOOTING

## GGG BOARD

### VIDEO

No video display on the Monitor. Check the clock waveform at pin 1 of Graphics Display Controller IC (9B). If the waveform is missing, refer to the "Video Clock and Dividers" section of this Troubleshooting guide. If the waveform is present, check Connectors CN10 and CN4 for good connections. If the waveform is missing at pin 6 of Connector CN10, check for a video waveform at pin 2 of IC 14C. If the waveform is present, check the voltages and components associated with Video Amp Transistor (Q1). If the waveform is missing at pin 2 of IC 14C, check for pulses at pins 9 and 11 of Flip/Flop IC (14D). If pulses are present at pin 9 of IC 14D, check IC 14D by substitution. If pulses are missing at pin 9 and present at pin 11 of IC 14D, check IC 14D by substitution. If pulses are missing at pin 11 of IC 14D, check Character Attribute Generator IC (9D) by substitution.

13C, check IC 13C by substitution. If the waveform is missing at pin 5 of IC 13C, check the waveforms at pins 2 and 3 of Flip/Flop IC (12E). If the waveforms are good at pins 2 and 3 of IC 12E, check IC 12E by substitution. If the waveform at pin 2 of IC 12E is missing, check Graphics Display Controller IC (9B) by substitution.

No horizontal sync. Check the waveform at pin 4 of IC 13C. If the waveform is present, check pin 18 of Connector CN10 and pin 4 of Connector CN4 for good connections. If the waveform is missing at pin 4 of IC 13C, check the waveform at pin 3 of IC 13C. If the waveform is present at pin 3 of IC 13C, check IC 13C by substitution. If the waveform is missing at pin 3 of IC 13C, check the waveforms at pins 11 and 12 of Flip/Flop IC (12E). If the waveforms are present at IC 12E, check IC 12E by substitution. If the waveform at pin 12 of IC 12E is missing, check Graphics Display Controller IC (9B) by substitution.

### VIDEO CLOCK AND DIVIDERS

Check the 16.667MHz Oscillator IC (14E) by checking for a frequency of 16.667MHz at pin 19 of Character Attribute Generator IC (9D). If the frequency is incorrect or the oscillator is not working, check IC 14E by substitution. If the oscillator checks good, check the waveform at pin 20 of IC 9D. If the waveform is missing, check IC 9D by substitution.

### SYNC

No vertical sync. Check the waveform at pin 6 of IC 13C. If the waveform is present, check pin 7 of Connector CN10 and pin 5 of Connector CN4 for good connections. If the waveform is missing at pin 6 of IC 13C, check the waveform at pin 5 of IC 13C. If the waveform is present at pin 5 of IC

## MISCELLANEOUS ADJUSTMENTS

### VIDEO LEVEL (GGG BOARD)

Connect the input of a scope to pin 6 of Connector CN10. Turn the computer on with no diskette in the disk drives (INSERT DISKETTE will appear on the monitor screen). Adjust VR1 on the GGG Board for a waveform of 4 volts peak to peak.

## SCHEMATIC NOTES

—\*— Circuitry not used in some versions

--- Circuitry used in some versions

• See parts list

⊕ Ground

⊖ Chassis

Waveforms and voltages taken from ground, unless noted otherwise

Voltages, Waveforms and Logic Probe readings for main board taken with Computer in Power Up mode, no keys pressed, unless otherwise noted.

Waveforms taken with triggered scope and Sweep/Time switch in Calibrate position, scope input set for DC coupling on 0 reference voltage waveforms. Switch to AC input to view waveforms after DC reference is measured when necessary. Each waveform is 7 cm. width with DC reference voltage given at the bottom line of each waveform.

Time in  $\mu$ sec. per cm, given with p-p reading at the end of each waveform.

Item numbers in rectangles appear in the alignment/adjustment instructions.

Supply voltages maintained as shown at input.

Controls adjusted for normal operation.

Terminal identification may not be found on unit.

Capacitors are 50 volts or less, 5% unless noted.

Electrolytic capacitors are 50 volts or less, 20% unless noted.

Resistors are  $\frac{1}{2}W$  or less, 5% unless noted.

Value in ( ) used in some versions.

Measurements with switching as shown, unless noted.

Logic Probe Display

L = Low

H = High

P = Pulse

\* = Open (No light On)

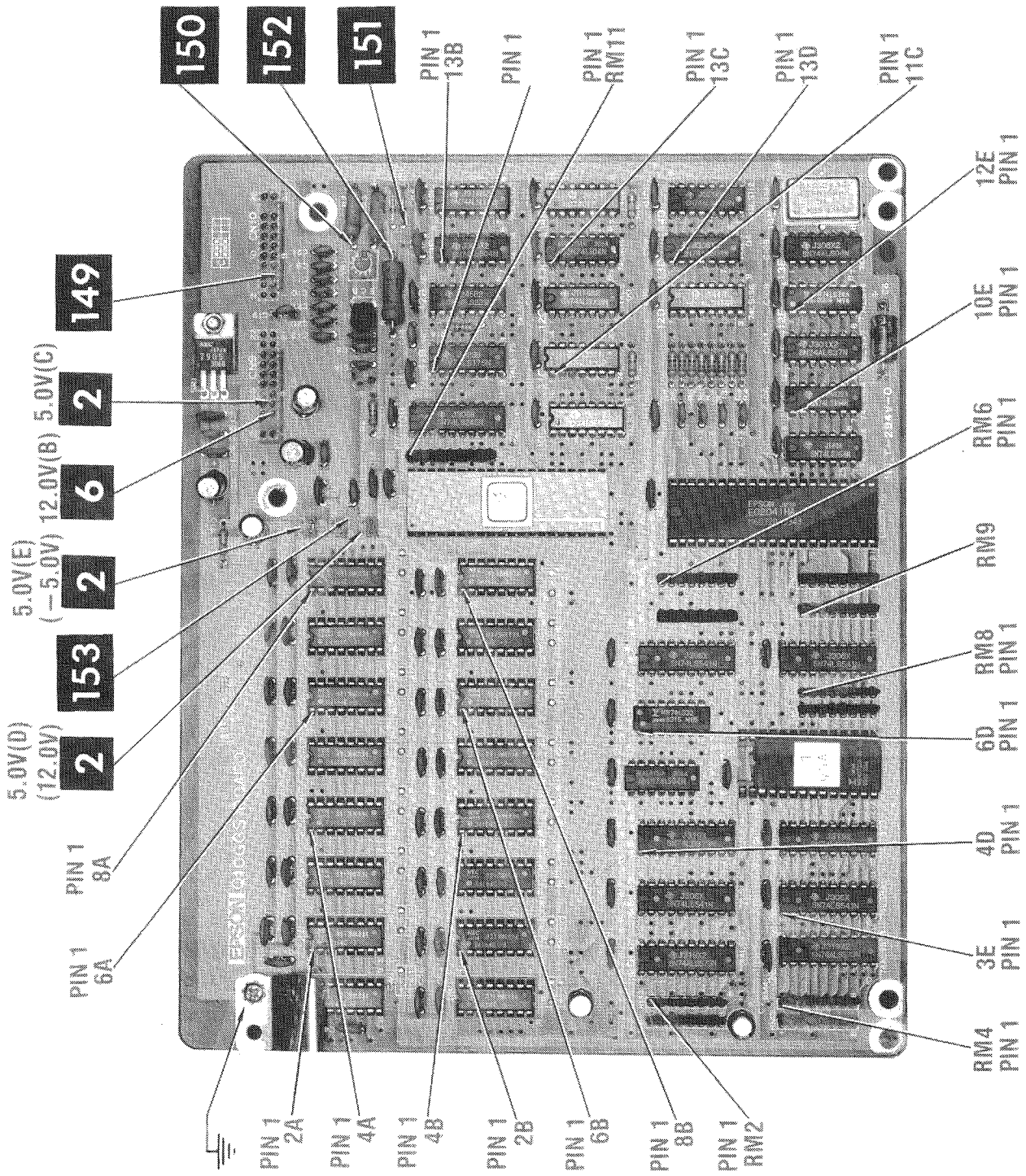

EPSON  
MODEL QX-10

GGS BOARD

A Howard W. Sams CIRCUITRACE® Photo

# IC PINOUTS & TERMINAL GUIDES

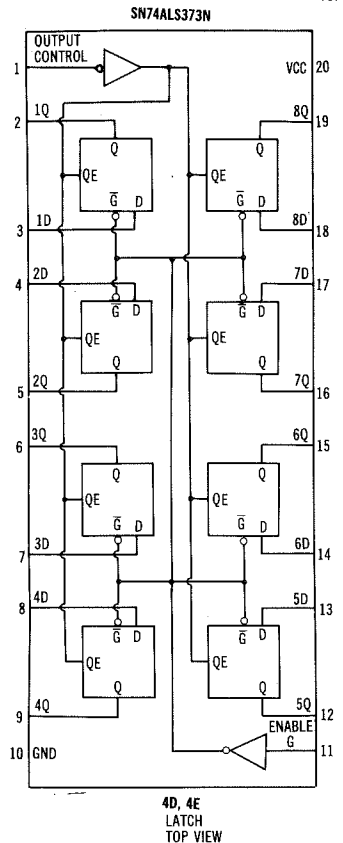
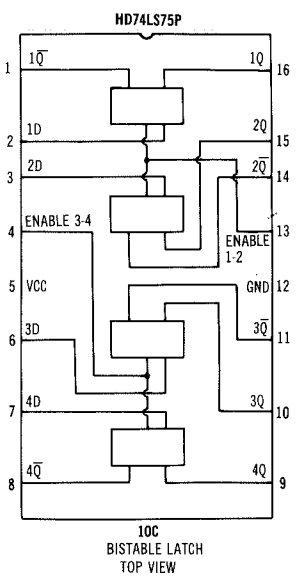
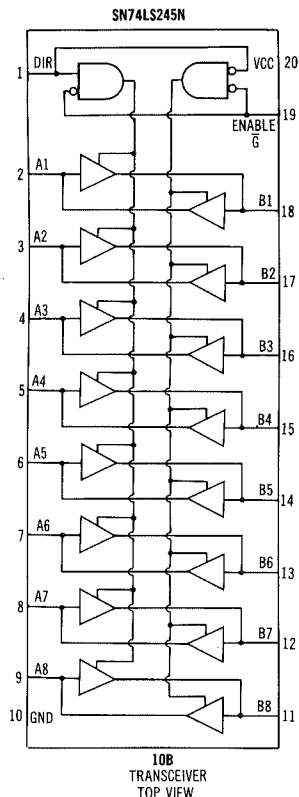
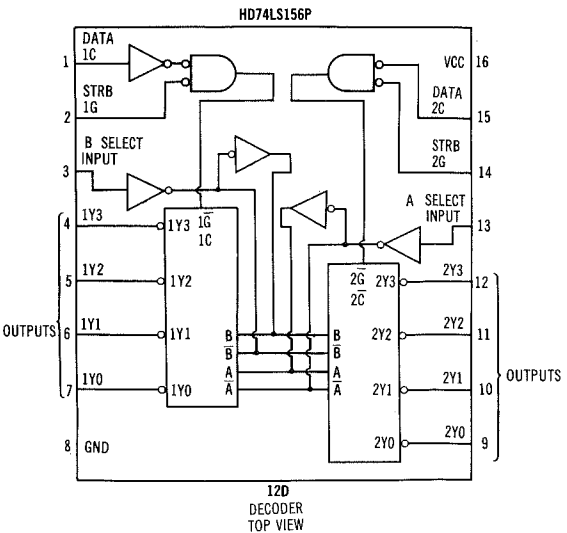
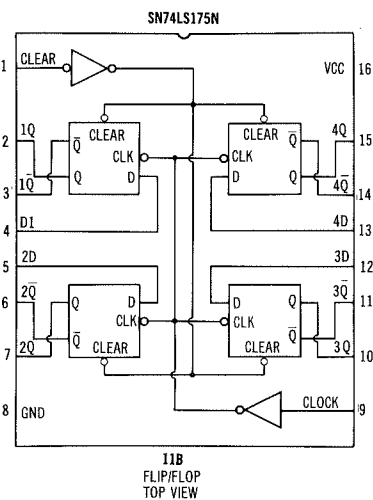
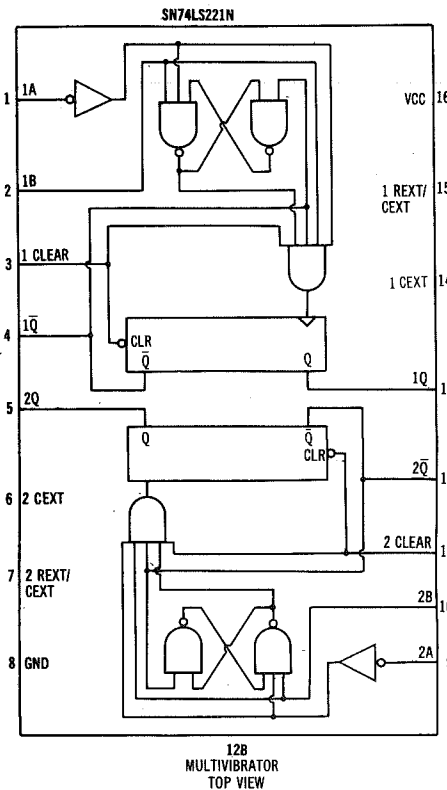
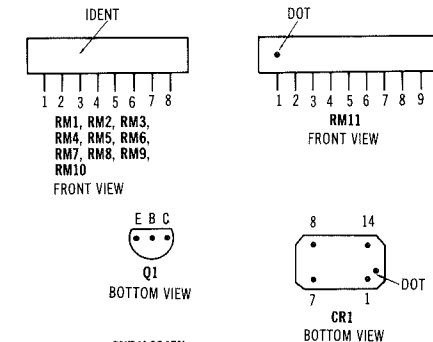
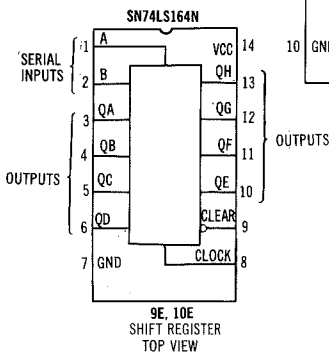
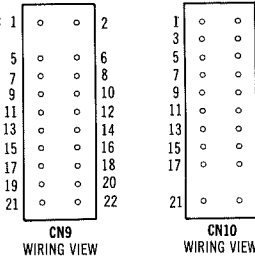
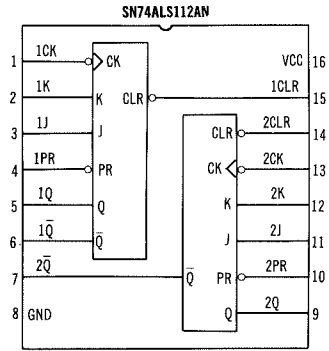
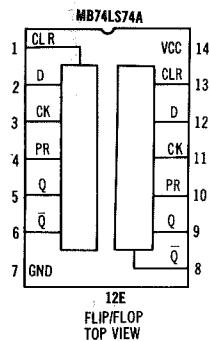
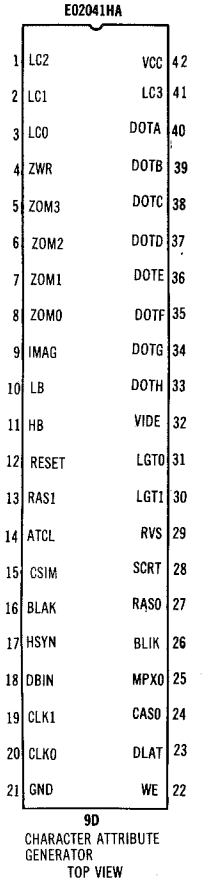
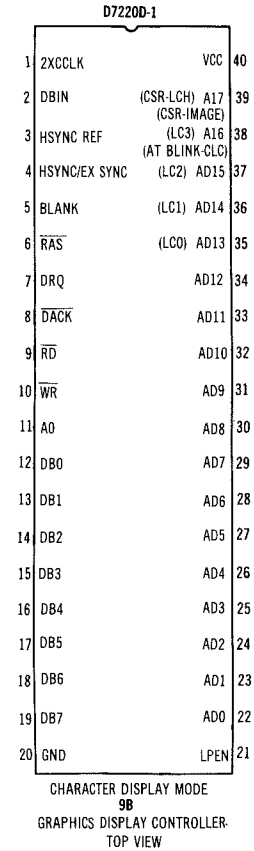
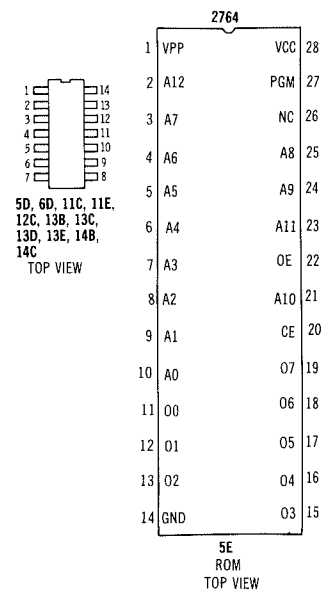
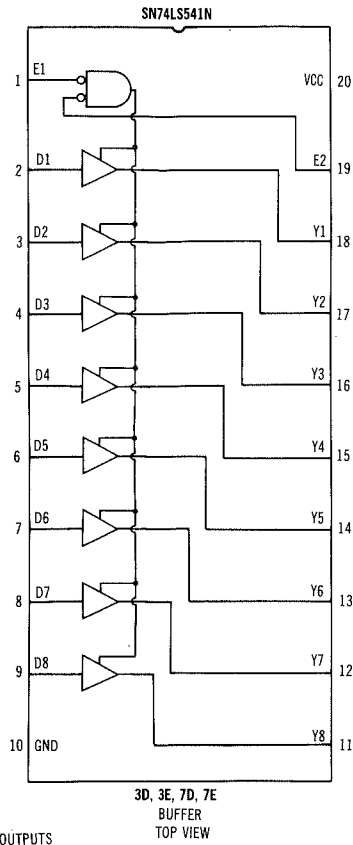
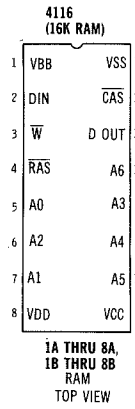
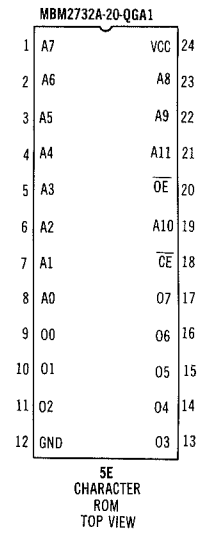
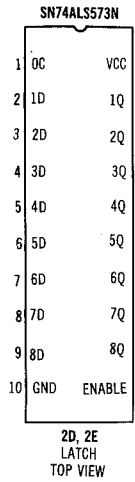
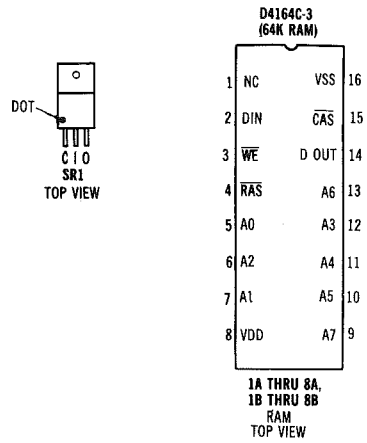

EPSON  
MODEL QX-10

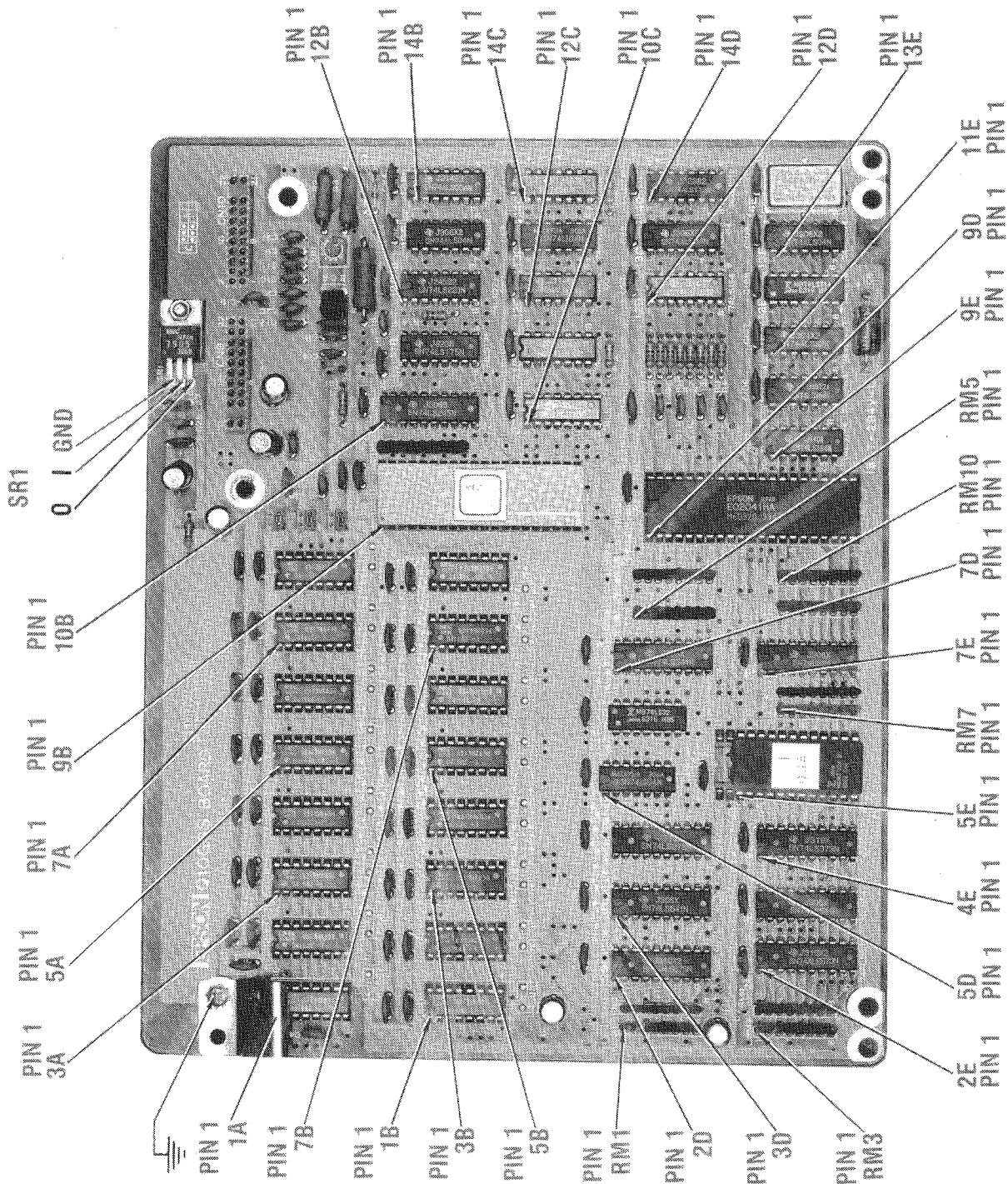

EPSON  
 MODEL QX-10

## PARTS LIST AND DESCRIPTION

When ordering parts, state Model, Part Number, and Description

### SEMICONDUCTORS (Select replacement transistor for best results)

ITEM No.	TYPE No.	MFR. PART No.	REPLACEMENT DATA						
			GENERAL ELECTRIC PART No.	NTE PART No.	PHILIPS ECG PART No.	RCA PART No.	WORKMAN PART No.	ZENITH PART No.	
<b>GGS BOARD</b>									
D1,2	1S2074H	X320010480	GE-300	NTE177	ECG177	SK9091/177	WEP1062/177	103-131	
Q1	2SC1284R	X302138400	GE-47	NTE293	ECG293	SK3849/293	WEP914/297	121-29066	
SR1	7905	X440069050	GE-961	NTE961	ECG961	SK3671/961		HE-442-630	
1A,B	79M05		GE-961	NTE961	ECG961	SK3671/961		HE-442-630	
	D4164C-3	X400104162	4164-15	NTE2117	ECG2164			HE-443-904	
2A,B	4116			NTE2117	ECG2117			HE-443-904	
	uPD416	X400104162	4164-15	NTE2117	ECG2117			HE-443-904	
2D,E	D4164C-3	X420505730		NTE2117	ECG2164			HE-443-904	
	4116			NTE2117	ECG2117			HE-443-904	
3A,B	uPD416	X400104162		NTE2117	ECG2117			HE-443-904	
	SN74ALS573N	X420305410		NTE74LS541	ECG74LS541			HE-443-904	
3D,E	D4164C-3	X400104162	4164-15	NTE2117	ECG2164			HE-443-904	
	4116			NTE2117	ECG2117			HE-443-904	
4A,B	uPD416	X400104162		NTE2117	ECG2117			HE-443-904	
	SN74LS541N	X420303730		NTE74LS373	ECG74LS373	SK74LS373		HE-443-904	
4D,E	D4164C-3	X400104162	4164-15	NTE2117	ECG2164			HE-443-904	
	4116			NTE2117	ECG2117			HE-443-904	
5A,B	uPD416	X420300040		NTE74LS04	ECG74LS04			HE-443-904	
	SN74LS04N		74LS04	NTE74LS04	ECG74LS04	SK74LS04		HE-443-867	
5D	D4164C-3	X400104162	4164-15	NTE2117	ECG2164			HE-443-904	
	4116			NTE2117	ECG2117			HE-443-904	
5E	uPD416	X420300040		NTE74LS04	ECG74LS04			HE-443-904	
	SN74LS04N		74LS04	NTE74LS04	ECG74LS04	SK74LS04		HE-443-755	
6A,B	MBM2732A-20-	Y130800701							
	QGA1								
	2764								
6D	Q6E-1	Y130800501(1)							
	D4164C-3	X400104162	4164-15	NTE2117	ECG2164			HE-443-904	
6D	4116			NTE2117	ECG2117			HE-443-904	
	uPD416	X420300320		NTE74LS32	ECG74LS32	SK74LS32		HE-443-875	
	MB74LS32		74LS32	NTE74LS32	ECG74LS32	SK74LS32			

# PARTS LIST AND DESCRIPTION (Continued)

When ordering parts, state Model, Part Number, and Description

## SEMICONDUCTORS (Select replacement transistor for best results)

ITEM No.	TYPE No.	MFR. PART No.	REPLACEMENT DATA						
			GENERAL ELECTRIC PART No.	NTE PART No.	PHILIPS ECG PART No.	RCA PART No.	WORKMAN PART No.	ZENITH PART No.	
7A,B	D4164C-3	X400104162	4164-15	NTE2117 NTE2117 NTE74LS541	ECG2164 ECG2117 ECG2117 ECG74LS541				HE-443-904 HE-443-904
	4116								
	uPD416								
7D,E	SN74LS541N	X420305410							
	D4164C-3	X400104162	4164-15	NTE2117 NTE2117	ECG2164 ECG2117 ECG2117				HE-443-904 HE-443-904
8A,B	4116	X400072200 Y130801301							
	uPD416								
9B	D7220D-1	X420301640 X420302450	74LS164 74LS245	NTE74LS164 NTE74LS245	ECG74LS164 ECG74LS245				
	E02041HA								
9E	SN74LS164N	X420300750	74LS75	NTE74LS75	ECG74LS75				HE-443-885 HE-443-781
	SN74LS175N	X420301750	74LS164 74LS175	NTE74LS164 NTE74LS175	ECG74LS164 ECG74LS175		SK74LS164 SK74LS175		HE-443-752
11C	HD74LS00P	X420300000	74LS00	NTE74LS00	ECG74LS00		SK74LS00		HE-443-728
	SN74ALS37N	X420500370							
12B	SN74LS221N	X420302210		NTE74LS221	ECG74LS221		SK74LS221		
	SN74AL500AN	X420500000							
12D	HD74LS156P	X420301560		NTE74LS156	ECG74LS156		SK74LS156		
	M874LS74A	X420300740	74LS74A	NTE74LS74A	ECG74LS74A		SK74LS74A		HE-443-730
13B	SN74ALS04N	X420500040		NTE74LS04	ECG74LS04		SK74LS04		HE-443-755
	SN74LS04N	X420300040	74LS04						
13D,E	SN74ALS04N	X420500040							
	SN74ALS00AN	X420500000							
14C	HD7406P	X420100060	GE-7406	NTE7406	ECG7406		SK7406		HE-443-698
	SN74ALS112AN	X420501120							

(1) Used in European Models.

EPSON  
MODEL QX-10

## PARTS LIST AND DESCRIPTION (Continued)

When ordering parts, state Model, Part Number, and Description

### RESISTORS (Power and Special)

ITEM No.	RATING	REPLACEMENT DATA		
		MFGR. PART No.	NEW-TONE PART No.	WORKMAN PART No.
RM1	Resistor Network (1)	X115443301		
RM2	Resistor Network (1)	X115443301		
RM3	Resistor Network (1)	X115443301		
RM4	Resistor Network (1)	X115443301		
RM5	Resistor Network (2)	X115444701		
RM6	Resistor Network (2)	X115444701		
RM7	Resistor Network (2)	X115444701		
RM8	Resistor Network (2)	X115444701		
RM9	Resistor Network (2)	X115444701		
RM10	Resistor Network (2)	X115444701		
RM11	Resistor Network (3)	X110885621		

(1) Contains four (4ea.) 33 10%.

(2) Contains four (4ea.) 47 10%.

(3) Contains eight (8ea.) 5600 10%.

### CONTROLS (All wattages 1/2 watt, or less, unless listed)

ITEM NO.	FUNCTION	RESISTANCE	MFGR. PART NO.	NOTES
VR1	Video Level	100	X180020090 3401(1)	

(1) Number on unit.

### MISCELLANEOUS

ITEM No.	PART NAME	MFGR. PART No.	NOTES
B1 CR1	Ferrite Bead Quartz Oscillator PC Board PC Board	Y130202002 X504004200 Y130216000 Y130215000	16.667MHz GGS, 128K, For U.S. (ASCII) GGS, 32K, For U.S. (ASCII), All Europe

# LOGIC CHART

PIN NO.	IC 1A	IC 1B	IC 2A	IC 2B	IC 2D	IC 2E	IC 3A	IC 3B	IC 3D	IC 3E	IC 4A	IC 4B	IC 4D	IC 4E
1	H	H	H	H	P	P	H	H	H	H	H	H	L	L
2	P	P	P	P	P	L	P	P	L	P	P	P	L	P
3	H	H	H	H	P	P	H	H	L	P	H	H	L	P
4	P	P	P	P	P	P	P	P	L	P	H	H	L	P
5	P	P	P	P	P	P	P	P	L	P	P	P	L	P
6	P	P	P	P	L	P	P	P	L	P	P	P	L	P
7	P	P	P	P	L	L	P	P	L	L	P	P	L	P
8	H	H	H	H	L	L	H	H	L	L	H	H	L	P
9	L	L	L	L	L	P	L	L	L	P	L	L	L	P
10	P	P	P	P	L	P	P	P	L	L	P	P	L	P
11	P	P	P	P	L	P	P	P	L	L	P	P	L	P
12	P	P	P	P	L	P	P	P	L	L	P	P	L	P
13	P	P	P	P	P	P	P	P	L	P	P	P	L	P
14	P	P	P	P	P	P	P	P	L	L	P	P	L	P
15	P	P	P	P	P	P	P	P	L	L	P	P	L	P
16	L	L	L	L	P	P	L	L	L	P	L	L	L	P
17					P	P			P	P			L	P
18					P	L			H	H			L	P
19					P	H			H	H			L	P
20					H	H			H	H			H	H
PIN NO.	IC 5A	IC 5B	IC 5D	IC 5E	IC 6A	IC 6B	IC 6D	IC 7A	IC 7B	IC 7D	IC 7E	IC 8A	IC 8B	
1	H	H	H	P	H	H	L	H	H	H	H	H	H	
2	P	P	L	P	L	P	P	L	L	L	P	L	L	
3	H	H	*	P	H	H	P	H	H	L	P	H	H	
4	P	P	L	P	P	P	*	P	P	L	P	P	P	
5	P	P	*L	P	P	P	H	P	P	L	P	P	P	
6	P	P	L	P	P	P	L	P	P	L	P	P	P	
7	P	P	L	P	P	P	H	P	P	L	P	P	P	
8	H	H	L	P	H	H	L	H	H	L	P	H	H	
9	L	L	*L	P	L	L	*	L	L	L	L	L	L	
10	P	P	*L	P	P	P	*	P	P	L	L	P	P	
11	P	P	L	P	P	P	H	P	P	L	L	P	P	
12	P	P	L	P	P	P	*	P	P	L	L	P	P	
13	P	P	H	P	L	L	H	P	P	P	P	P	L	
14	L	L		P	L	L		L	L	P	P	L	L	
15	P	P		P	P	P		P	P	P	P	P	L	
16	L	L		P	L	L		L	L	P	P	L	L	
17				L						P	P			
18				L						H	H			
19				L						H	H			
20				L						H	H			
21				L										
22				P										
23				P										
24				H										

Logic Probe Display

L = Low

H = High

P = Pulse

\* = Open (No light On)

Note: Logic probe readings taken with computer turned On, no keys pressed, unless otherwise noted.

## LOGIC CHART (Continued)

**EPSON**  
**MODEL QX-10**

PIN NO.	IC 9B	PIN NO.	IC 9B	PIN NO.	IC 9D	PIN NO.	IC 9D	PIN NO.	IC 9E	IC 10B	IC 10C	IC 10E	IC 11B
1	P	21	L	1	P	22	L	1	P	H	H	P	H
2	H	22	P	2	P	23	P	2	P	P	P	P	P
3	P	23	P	3	P	24	P	3	P	P	P	P	P
4	P	24	P	4	L	25	P	4	P	P	L	P	P
5	P	25	P	5	L	26	L	5	P	P	H	P	P
6	P	26	P	6	L	27	L	6	P	P	P	P	P
7	L	27	P	7	L	28	L	7	L	P	P	L	P
8	H	28	P	8	L	29	L	8	P	P	H	L	L
9	H	29	P	9	L	30	L	9	H	P	L	H	P
10	H	30	P	10	H	31	H	10	P	L	L	P	P
11	P	31	P	11	H	32	P	11	P	L	L	P	P
12	P	32	P	12	L	33	P	12	P	P	H	P	P
13	P	33	L	13	P	34	P	13	P	P	L	P	*
14	P	34	L	14	P	35	P	14	H	P	H	H	L
15	P	35	L	15	L	36	P	15		P	L		H
16	P	36	L	16	P	37	P	16		P	L		H
17	P	37	L	17	P	38	P	17		P			
18	P	38	P	18	H	39	P	18		L			
19	P	39	L	19	P	40	L	19		L			
20	L	40	H	20	P	41	P	20		H			
				21	L	42	H						
PIN NO.	IC 11C	IC 11E	IC 12B	IC 12C	IC 12D	IC 12E	IC 13B	IC 13C	IC 13D	IC 13E	IC 14B	IC 14C	IC 14D
1	P	*	H	P	P	H	H	P	H	*	L	P	P
2	P	*	H	P	P	P	L	P	L	L	H	P	L
3	P	L	H	P	P	H	L	P	H	P	H	H	H
4	H	P	H	H	H	H	H	P	L	P	P	L	H
5	H	L	L	L	H	P	P	P	L	P	L	P	H
6	L	H	H	H	H	P	P	P	L	P	L	P	L
7	L	L	L	L	H	L	L	L	L	L	H	L	L
8	L	P	L	L	L	L	P	L	P	L	L	P	L
9	L	P	*	H	P	P	P	H	P	*	P	P	P
10	P	P	*	H	H	H	P	P	P	P	L	L	H
11	H	P	*	L	*	P	P	P	P	L	L	H	P
12	L	P	H	H	*	P	P	P	L	L	H	P	P
13	L	P	L	H	P	H	H	P	*	*	H	P	P
14	H	H	H	H	P	H	H	H	H	H	H	H	H
15			*		P								H
16			H		H								H

Logic Probe Display

L = Low

H = High

P = Pulse

\* = Open (No light On)

Note: Logic probe readings taken with computer turned On, no keys pressed, unless otherwise noted.

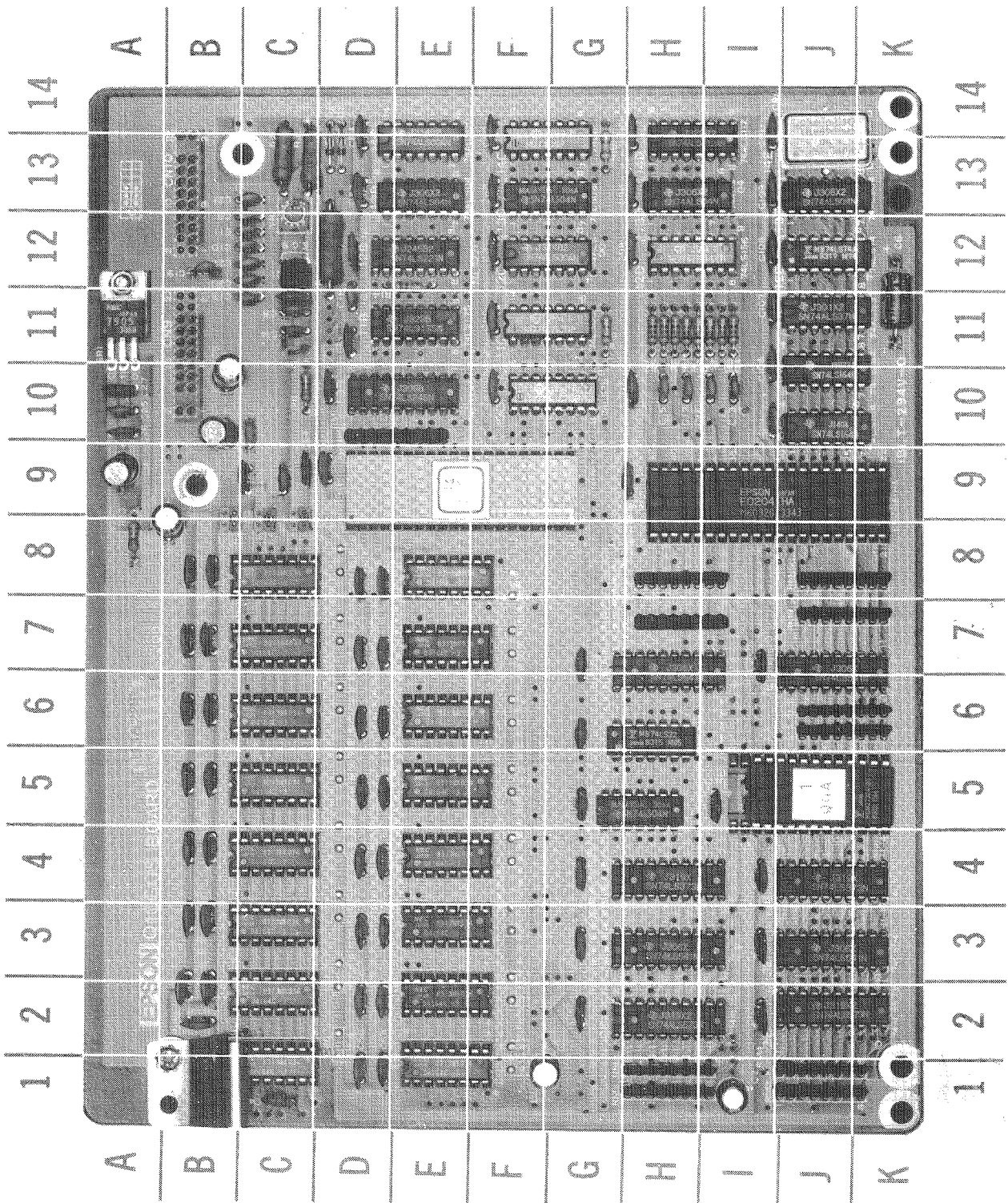

**GGG BOARD**

A Howard W. Sams **GRIDTRACE™** Photo

## GridTrace LOCATION GUIDE

B1	C-11	C89	F-14	5A	C-5
C1	B-10	C90	I-2	5B	E-5
C2	B-8	C91	G-3	5D	H-5
C3	F-1	C92	G-4	5E	J-5
C4	A-9	C93	G-5	6A	C-6
C5	B-10	C94	G-6	6B	E-6
C6	K-11	C95	G-7	6D	H-6
C7	I-1	C96	H-9	7A	C-7
C8	C-11	C97	H-10	7B	E-7
C9	C-12	C98	H-12	7D	H-7
C10	C-12	C99	H-13	7E	J-7
C11	C-12	C100	H-14	8A	C-8
C12	C-11	C101	I-2	8B	E-8
C13	I-10	C102	I-3	9B	E-9
C14	C-11	C103	I-4	9D	I-9
C15	H-10	C104	I-5	9E	J-10
C16	H-10	C105	I-7	10B	D-10
C17	H-10	C106	I-11	10C	F-10
C18	D-11	C107	I-11	10E	J-10
C19	B-12	C108	I-12	11B	E-11
C20	C-12	C109	I-13	11C	F-11
C21	C-13	C110	I-14	11E	J-11
C22	C-12	C111	I-10	12B	E-12
C23	C-9	CR1	J-14	12C	F-12
C24	B-10	D1	D-13	12D	H-12
C25	A-10	D2	D-13	12E	J-12
C26	A-10	J1	B-8	13B	E-13
C27	A-10	J2	C-8	13C	F-13
C28	C-11	J3	C-8	13D	H-13
C29	C-9	Q1	C-12	13E	J-13
C30	B-2	R1	D-12	14B	E-13
C31	B-2	R2	C-13	14C	F-13
C32	B-3	R3	C-13	14D	H-13
C33	B-4	R4	I-11		
C34	B-5	R5	H-11		
C35	B-6	R6	H-11		
C36	B-7	R7	H-11		
C37	B-8	R8	C-10		
C38	B-2	R9	I-11		
C39	B-3	R10	A-8		
C40	B-4	R11	H-11		
C41	B-5	R12	H-11		
C42	B-6	R13	J-11		
C43	B-7	R14	E-12		
C44	B-8	R15	G-11		
C45	C-1	R16	G-13		
C54	C-9	RM1	H-1		
C55	D-10	RM2	H-1		
C56	D-1	RM3	J-1		
C57	D-2	RM4	J-1		
C58	D-3	RM5	H-7		
C59	D-4	RM6	H-8		
C60	D-5	RM7	J-6		
C61	D-6	RM8	J-6		
C62	D-7	RM9	J-7		
C63	D-8	RM10	J-8		
C64	D-1	RM11	D-10		
C65	D-2	SR1	A-11		
C66	D-3	VR1	C-12		
C67	D-4	1A	C-1		
C68	D-5	1B	E-1		
C69	D-6	2A	C-2		
C70	D-7	2B	E-2		
C71	D-8	2D	H-2		
C80	D-10	2E	J-2		
C81	D-10	3A	C-3		
C82	D-11	3B	E-3		
C83	D-13	3D	H-3		
C84	D-13	3E	J-3		
C85	F-10	4A	C-4		
C86	F-11	4B	E-4		
C87	D-12	4D	H-4		
C88	F-13	4E	J-4		

# LINE DEFINITIONS

A0 Thru A15	Address Lines	e1 Thru e3	
AA		E1	
AAB		E	
AB		EA	
AB0 Thru AB15		EB	
ACK	Acknowledge	EE	
AD0 Thru AD15	Bidirectional Address Lines	EEA	
ADR0 Thru ADR15	Address Lines	EOP	
ALF	Autoline Feed	EOPF	End of Process
B		EOPS	End of Process
BA		ERR	Error
BB		F	
BB1		FA	
BBA		FF	
BD0 Thru BD7	Bidirectional Data Lines	FFA	
BD0A Thru BD15A	Bidirectional Data Lines	g1	
BSAK	Bus Acknowledge	g4	
C		G	
CA		GA	
CA0 Thru CA7		GG	
CCA		GGA	
CASA		HA	
CAS1 Thru CAS4		HDS	Side Select
CAS		HH	
CC		HHA	
CD0 Thru CD15		HLD	Head Load
CE	Control Enable	HSYNC	Horizontal Sync
CES		I	
CLK		IA	
CLKA		II	
CS	Chip Select	IIA	
CS-1		IMAG	
CSCCR	CRT Drive Board Select	INT	Interrupt Request
CSCRT	CRT Drive Board Select	INDX	Index
CTS	Clear to Send	INTCR	Light peninterrupt request
d		INTF1 & INTF2	
d6 Thru d8		INTR	Interrupt Request
D		INTSL1 Thru INTSL4	
D0 Thru D7	Data Lines	IORD	Input/Output Read
DA		IOWD	Input/Output Write
DAA		IRD	I/O Read
DACK	Data Acknowledge	IR0	
DACK-2	DMA Acknowledge	IRQ7	
DAK	Acknowledge	IWR	I/O Write
DAK1 Thru DAK4		IWS	
DAKF	DMA Acknowledge	J1 Thru J7	
DAKS1 Thru DAKS4	DMA Acknowledge	J	
DB		JA	
DB1 Thru DB7	Data Line	JJ	
DBIN	Data Buffer Input	JJA	
DCD	Data Carrier Detect	K1 Thru K6	
DD		K	
DLATCH	Data Latch	KA	
DIR	Direction	KK	
DOTA Thru DOTH		KKK	
DREQ	Data Request	L	
DREQ-1 Thru DREQ-2	DMA Transfer Request	LA	
DRQF	DMA Request	LC0 Thru LC3	
DRQS1 Thru DRQS4	DMA Request	LGT1	
DSR		LL	
DTB0 Thru DBT7	Data Lines	LLA	
DTR	Data Terminal Ready		

## LINE DEFINITIONS (Continued)

M3 Thru M10	Memory Lines	RR	
M		RTS	Request to Send
MA		RXC	Receive Clock
MA0 Thru MA7	Memory Address Lines	RXD	Received Data
MD0 Thru MD15	Data Lines	RXDA	
MEG		RUS	
MEMX	External Memory select	S	
MM		SA	
MMA		SEL	Select
MRD	Memory Read	SIG	Light Pen Signal
MT	Motor On	SCRT	
MW		SLO	Select Out
MWR	Memory Write	SS	
N		STB	Strobe
NA		SQW	
NN		SW	Light Pen Switch
NNA		STP	Step
OA		T	
OC		TA	
OO		TO	Track 0
OOA		TXD	Transmitted Data
OUT2		TT	
P		U	
PA		UA	
PP		UA0 Thru UA7	
PPA		UB0 Thru UB15	
PRI	Priority Output	UD0 Thru UD7	
PWF	Power Failure	US0 Thru US3	
PWD	Power Failure Detection	VA	
Q		VSYNC	Vertical Sync
QA		W	
QE		W1 Thru W4	
QQ		WA	
QQA		WAIT	Wait
R		WCLK	Write Clock
RA		WD	Write Data
RAS	Row Address Strobe	WG	Write Gate
RAS1 Thru RAS4		WINDOW	
RD	Read Data	WR	Write
RD-1 & RD2	Read Data	WRT	Write
RDY	Ready	X	
RDYF	DMA Ready	Y	
RDYS	DMA Ready	Z	
RES		ZA	
RESET	Reset	Ø	Single Phase Clock
RESET-1 & RESET-2	Reset	ØCLK	Phase Clock
REV	Reverse Channel	3M	
RFSH	Refresh	4	
RFSH-1 & H-2	Refresh	10RD	Read Data
RSIN	Reset Input	10WR	Write Data Strobe
RST	Reset		

Any Bar above any alphabetical or numerical combination indicates line active in a low (0) state.