

EPSON
MODEL QX-10

CSCS4-C

ASCII KEYBOARD
HASCII KEYBOARD
POWER SUPPLY BOARD
SYSTEM BOARD
 See Folder CSCS4

CSCS4-C

EPSON
MODEL QX-10**INDEX**

	Page		Page
GridTrace Location Guide		Photos (Continued)	
Drive Motor Board	13	Main Board	7,8,14
Main Board	8	Schematics	
Miscellaneous Adjustments	17,18	Disk Drive	2
Parts List	9,10,11,12	IC Pinout and Terminal Guide	3
Photos		Notes	19
Drive Motor Board	13,15	Troubleshooting	4,5,6
Disk Drive-Top View	20		
Mechanical-Top View	21		

SAMS™**Howard W. Sams & Co., Inc.**

4300 West 62nd Street, P.O. Box 7092, Indianapolis, Indiana 46206 U.S.A.

The listing of any available replacement part herein does not constitute in any case a recommendation, warranty or guaranty by Howard W. Sams & Co., Inc., as to the quality and suitability of such replacement part. The numbers of these parts have been compiled from information furnished to Howard W. Sams & Co., Inc., by the manufacturers of the particular type of replacement part listed.

Reproduction or use, without express permission, of editorial or pictorial content, in any manner, is prohibited. No patent liability is assumed with respect to the use of the information contained herein.

© 1985 Howard W. Sams & Co., Inc.

4300 West 62nd Street, P.O. Box 7092, Indianapolis, Indiana 46206 U.S.A.

Printed in U.S. of America.

84CS14930**DATE 4-85**

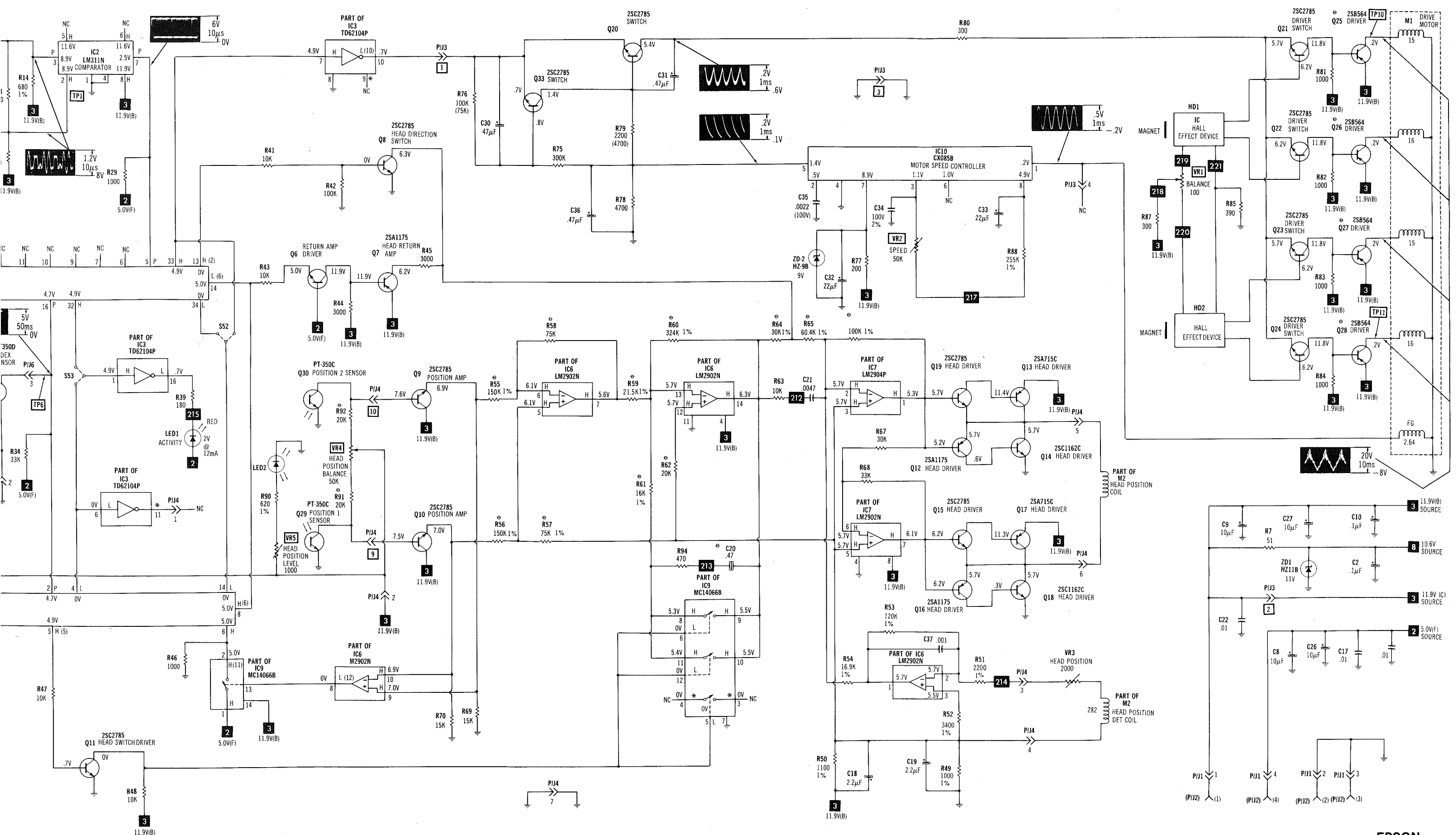

EPSON
MODEL QX-10

IC PINOUTS & TERMINAL GUIDES

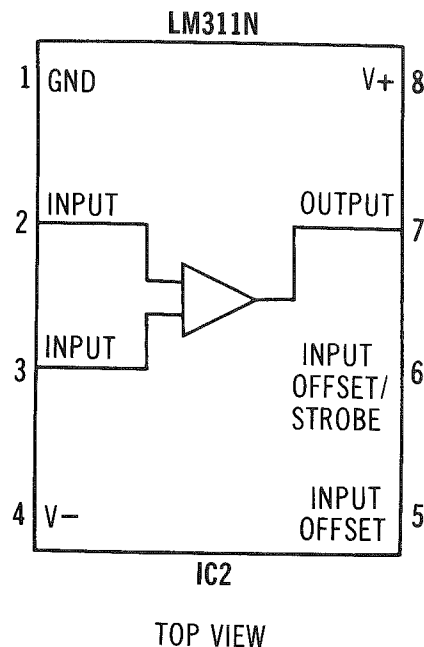
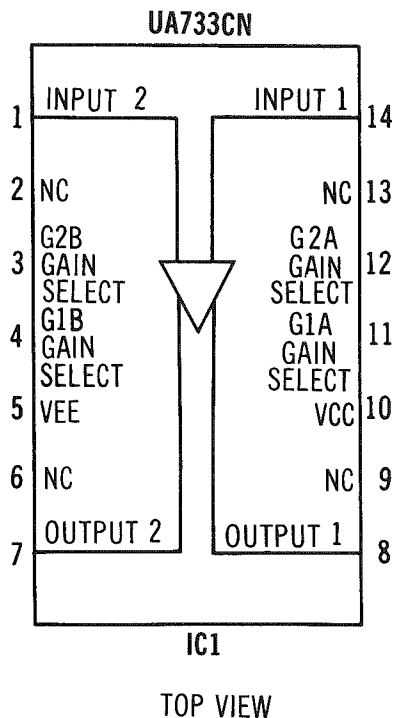

CSCS4-C

MODEL QX-10

EPSON

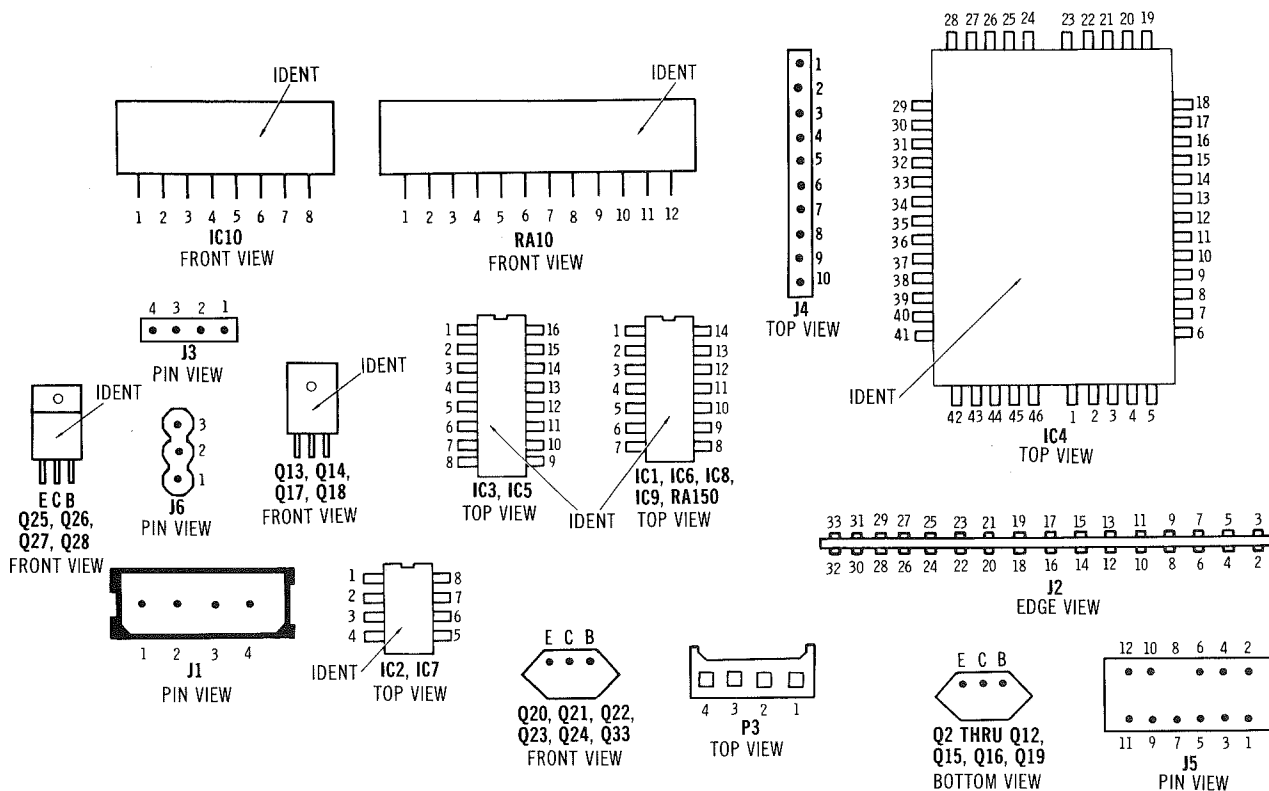

TROUBLESHOOTING

TEST SETUP

Connect Disk Drive known to be operating properly to the Computer as Disk Drive A. Connect the defective Disk Drive as Disk Drive B. Use Disk Drive A to load any alignment or test program needed to check the defective Disk Drive.

WARNING: It is possible for a defective Disk Drive to write on or erase information on a diskette, even if the diskette is write protected. Check the Disk Drive by first using a diskette that has programs which have been backed-up on another diskette. Do not leave the alignment diskette in the Disk Drive while checking voltages and waveforms unless specified in the alignment procedures. Test equipment may cause the Disk Drive circuits to erase sections of the alignment diskette even if the diskette is write protected.

DIRECT OPERATION OF DISK DRIVE

Load MBASIC into the Computer and type in and run the following program. This program will cause both Disk Drives to run continuously in read mode with the Side 0 head activated. Press the CTRL and C keys at the same time to stop the program. The Disk Drives will stop running after one minute.

```
1 OUT 48,18: GOTO 1
```

FLOPPY DISK CONTROLLER CLOCK

Verify that the Floppy Disk Controller Clock is operating properly by checking the waveforms at pins 8 and 10 of IC 17H on the System Board. If the waveforms are missing, check the waveform at pin 2 of IC 17H. If the waveform is missing at pin 2, check the 8MHz Crystal (CR3), Capacitor C44, Resistors R59 and R65 and also check IC 17H by substitution. If the waveform is present at pin 2 of IC 17H, check IC 17H, IC 18H and Counter IC (19H) by substitution. Check for a frequency of 8.00MHz at pin 2 of IC 17H. If the frequency is incorrect, check the Crystal CR3 and Capacitor C44.

DISK DRIVE CLOCK

To verify that the Disk Drive Clock is operating properly, check the waveform at pin 12 of IC (IC5). If the waveform is missing, check the waveform at pin 10 of IC5. If the waveform is missing at pin 10, check the 445kHz Crystal (X), Capacitors C13 and C14, Resistor R36 and also check Disk Head Control IC (IC5) by substitution. If the waveform is present at pin 10, check IC5 by substitution. Check for a frequency of 445kHz at pin 10 of IC5. If the frequency is incorrect, check the 445kHz Crystal X and Capacitors C13 and C14.

WILL NOT READ

Refer to the "Floppy Disk Controller Clock" and "Disk Drive Clock" sections of this Troubleshooting guide to verify that the clocks are operating properly. Load MBASIC into the Computer and type and run the following program.

```
1 OUT 48, 18: GOTO 1
```

This program will keep both Disk Drives running in read mode with the Side 0 Head activated. To verify that Disk Drive is in read mode, check for a High Logic reading at pin 24 of Connector J2. If the Logic reading is Low, check for a High Logic reading at pin 8 of IC 7C on the System Board. If the Logic reading at pin 8 is High, check pin 24 of Connectors CN6 and J2 for good connections and also check the cable for possible open wires. If pin 8 of IC 7C reads Logic Low, check for a Low Logic reading at pin 9 of IC 7C. If pin 9 reads Logic Low, check IC 7C by substitution. If pin 9 reads Logic High, check Disk Controller IC (14H) by substitution.

If the Logic reading at pin 24 of Connector J2 is High, insert a diskette into the Disk Drive and close the drive door. The diskette should be filled with programs to insure the head is reading information from the diskette. Check for a Low Logic reading at pin 12 of IC IC3. If pin 12 reads a Logic High, check for a High Logic reading at pin 5 of IC3. If pin 5 reads a Logic High, check IC3 by substitution. If pin 5 reads Low, check the resistance from pin 9 to pin 10 of Resistor Pack (RA10) and also check Disk Drive Control IC (IC4) by substitution. If pin 12 of IC3 reads a Logic Low, check the waveforms at pins 7 and 8 of Read Amp IC (IC1). If the waveforms are missing, check Diodes D1 thru D10, and the Head windings for open circuits. Also check Connector J5 for good connections and all the voltages and components associated with pin 1, 4, 5, 7, 8, 10, 11 and 14 of IC1. If the waveforms are good at IC1, check the waveforms at pins 2 and 3 of Comparator IC (IC2). If the waveforms are missing, check the voltages and components associated with Read Amp Transistors (Q2 and Q3). If the waveforms are present at pins 2 and 3 of IC2, check the waveform at pin 7 of IC2. If the waveform is missing, check the voltages and components associated with pins 1 thru 8 of IC2. If the waveform is good at pin 7 of IC2, check the waveform at pin 11 of IC (IC8). NOTE: There should be waveforms present at pin 7 of IC2 and pin 11 of IC8 even when the Disk Drive is not running. There should be a noticeable change in the waveforms when a diskette has been inserted into the Disk Drive, the drive door closed, and the Disk Drive is running. If the waveform is missing at pin 11 of IC8, check IC4 by substitution. If the waveform is present at pin 11 of IC8, check the waveform at pin 10 of IC8. If the waveform is missing, check IC8 by substitution.

INDEX DETECTOR

Verify that the index detector is working by checking the waveform at pin 17 of Disk Controller IC (14H) on the System Board when the Disk Drive is running. If the waveform is missing, check for pulses at TP6 (pin 3 of Connector J6) on the Disk Drive Board. If pulses are missing, check LED5, Index Sensor Photo Transistor (Q32) and check Connector J6 for good connections. If pulses are present at TP6, check for pulses at TP7 (pin 5 of IC8). If pulses are missing, check Disk Drive Control IC (IC4) by substitution. If pulses are present at TP7, check for pulses at pin 6 of (IC8). If pulses are missing, check IC3 by substitution. If pulses are missing at pin 1, check pin 8 of Connectors CN6 and J2 for good connections and also check the cable for possible open wires. If pulses are present at pin 1, check IC 11C by substitution.

TROUBLESHOOTING (Continued)

HEAD POSITION MOTOR DOES NOT WORK

Check the resistance readings on the Head Position Coil and Head Position Detector Coil (M2) and also check Connector P4 for good connections.

Use a Disk Drive Test program which will step the Head back and forth or connect the Disk Drive to a Disk Drive Tester that can step the Head. Use a test mode that will step the Head back and forth continuously between tracks 00 and 39 and check for pulses at pin 8 of Disk Head Control IC (IC5) and pin 13 of Disk Drive Control IC (IC4). Pulses should appear at pin 8 of IC5 when the head is moving away from the spindle and then at pin 13 of IC4 when the Head is moving toward the spindle. If pulses are missing, check IC5 and IC4 by substitution. If pulses are present, use a scope and check for pulses at the collector of Head Direction Switch Transistor (Q8). The pulses should be positive going (6V to 12V) when the Head moves away from the spindle and negative going (6V to 0V) when the Head moves toward the spindle. If the pulses are missing, check the voltages and components associated with Transistors Q6, Q7 and Q8. If pulses are present at the collector of Transistor Q8, check for a 10V peak to peak waveform (see Figure 6) at pin 1 of IC IC7 and pin 5 of Connector J4. If the waveform is missing at pin 1 of IC7, check the voltages and components associated with pins 1, 2 and 3 of IC7. If the waveform is missing at pin 5, of Connector J4, check the voltages and components associated with Head Driver Transistors (Q12, Q13, Q14 and Q19). If the waveforms check normal, check for a 10V peak to peak waveform at pin 7 of IC7 and pin 6 of Connector J4. The waveforms should be inverted but look like Figure 6. If the waveform is missing at pin 7 of IC7, check the voltages and components associated with IC7. If the waveform is missing at pin 6 of Connector J4, check the voltages and components associated with Head Driver Transistors (Q15 thru Q18).

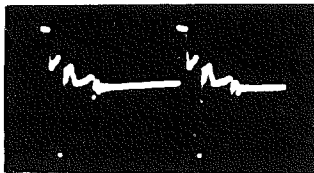

Figure 6

Check Position Amp Transistors (Q9 and Q10) and ICs IC6 and IC9 by checking waveforms while moving the Head back and forth by hand (with power On). Check for a 7V peak to peak sinewave waveform at pins 9 and 10 of Connector J4. If the waveforms are missing, check Position 1 and Position 2 Photo Transistors (Q29 and Q30), LED LED2 and check Connector J4 for good connections. If the waveforms are present, check for 6V peak to peak sinewave waveforms at pins 9 and 10 of IC6. If the waveforms are missing, check Transistors Q9 and Q10 and Resistors R69 and R70. If the waveforms are present, check for 7V peak to peak sinewave waveforms at pins 7 and 14 of IC6. If the waveforms are missing, check the voltages and components associated with pins 5, 6, 7, 12, 13 and 14 of IC6. If the waveforms are present, check for 12V pulses at pin 13 of IC IC9 and 5V pulses at pin 1 of IC9. If pulses are missing at pin 13, check IC6 by substitution. If pulses are missing at pin 1 of IC9, check IC9 by substitution.

TRACK 00 INDICATOR

Verify that the Track 00 Indicator is working by checking for a Low Logic reading at pin 26 of Connector J2 when the head is on track 00 and a High Logic reading when the head is off track 00.

If the logic readings are incorrect, check for a High Logic reading with the head off track 00 and a Low logic reading with the head off track 00 at pin 9 of IC (IC8) and pin 8 of Connector J4. If the readings are incorrect at pin 8 of Connector J4, check the Track Sensor Photo Transistor (Q31) and LED LED-3. If the readings are incorrect at pin 9 of IC8, check Disk Drive Control IC (IC4) by substitution. If the reading is correct at pin 9 of IC8, check IC8 by substitution.

SIDE SELECT

Load MBASIC into the Computer. Type and run the following program to keep the Disk Drive running continuously with Head 0 On.

```
1 OUT 48, 18: GOTO 1
```

Check for a High Logic reading at pin 32 of Connector J2. If the reading is incorrect, check for a High Logic reading at pin 6 of IC 7A on the System Board. If pin 6 reads a Logic High, check pin 32 of Connectors CN6 and J4 for good connections and check the cable for possible open wiring. If pin 6 reads a Logic Low, check for a Low Logic reading at pin 4 of IC 7A. If pin 4 reads a Logic Low and pin 5 of IC 7A reads a Logic High, check IC 7A by substitution. If pin 4 reads Logic High, check Disk Controller IC (14H) by substitution.

If the logic reading is correct at pin 32 of Plug J2, verify the operation of the Disk Drive side select circuits by checking the collector voltages of Side Select Transistors (Q4 and Q5) with pin 32 of Connector J2 grounded and then again with pin 32 ungrounded. With pin 32 grounded the collector of Transistor Q4 should measure 5V and the collector of Transistor Q5 should measure 0V. With pin 32 ungrounded the collector of Transistor Q4 should measure 0V and the collector of Transistor Q5 should measure 5V. If the readings are incorrect, check the resistance between pins 11 and 12 of Resistor Pack RA10 and resistors R30 and R31. Also check Q4, Q5 and IC4 by substitution. Check Connector J5 for good connections and the Head windings for possible open circuits.

ERASE CIRCUIT

Verify that the Erase sections of Heads are not open by checking the erase windings resistance between pins 2 and 6 of Connector J5 for Head 0 and between pins 1 and 5 of Connector J5 for Head 1. Type and run the program used for the Disk Drive voltage and logic probe measurements.

With the program running, check for pulses at pins 1 and 2 of Connector J5. If pulses are missing, check for pulses at pin 15 of IC3. If pulses are present at pin 15, check Diodes D11 and D12 and Resistors R26 and R27. If pulses are present at pin 15, check for pulses at pin 2 of IC3. If pulses are present at pin 2, check IC3 by substitution. If pulses are missing from pin 2 of IC3, check Disk Drive Control IC (IC4) by substitution.

The operation of the Side Select Transistors (Q4 and Q5) can affect the operation of the erase circuit. Refer to the "Side Select" section of this Troubleshooting guide for procedures on checking the side select circuit.

CSCS4-C
EPSON
MODEL QX-10

TROUBLESHOOTING (Continued)

WILL NOT WRITE

To verify that the write protect detector circuit is working properly, check for a Low Logic reading at pin 34 of Disk Controller IC (14H) with no diskettes in the Disk Drive. If the Logic reading is not Low, refer to the "Write Protect Does Not Work" section of this Troubleshooting guide.

Refer to the "Floppy Disk Controller Clock" and "Disk Drive Clock" sections of this Troubleshooting guide to verify that the clocks are operating properly.

Type and run the program used for the Disk Drive voltage and logic probe measurements. Check for pulses at pin 30 of IC 14H on the System Board. If pulses are missing, check IC 14H by substitution. If pulses are present, check for pulses at pin 6 of IC 7C. If pulses are missing at pin 6 of IC 7C check IC 7C by substitution. If pulses are present at pin 6 of IC 7C, check for pulses at pin 22 of Connector J2 on the Disk Drive Board. If pulses are missing, check pin 22 of Connectors CN6 and J2 for good connections and check the cable wire for possible open circuits. If pulses are present at pin 22 of Connector J2, check the waveform at pin 8 of Resistor Pack RA10. If the waveform is missing, check the resistance from pin 7 to pin 8 of Resistor Pack RA10. If the waveform is good, check for pulses at pins 3 and 4 of IC IC3. If pulses are missing, check Disk Drive Control IC (IC4) by substitution. If pulses are present, check for pulses at pins 13 and 14 of IC3. If pulses are missing, check IC3 by substitution. If pulses are present, check Resistors R22, R23, R12 and R13 and Diodes D3, D5, D8 and D10.

WRITE PROTECT DOES NOT WORK

If a write protected diskette is being written on, insert a write protected diskette into the Disk Drive, close the door, and check for a High Logic reading at the collector of Write Protect Photo Transistor (Q1). If the Logic reading is Low, check Photo Transistor Q1 for a short from the emitter to the collector. If the Logic reading checks High, check for pulses at pin 1 of IC8. If pulses are missing, check IC8 by substitution. If pulses are present at pin 1 of IC8, check for pulses at pin 2 of IC8. If pulses are missing at pin 2, check IC8 by substitution. If pulses are present at pin 2, check for pulses at pin 11 of IC 11C on the System Board. If pulses are missing at pin 11, check pin 28 of Connectors CN6 and J2 for good connections. Check the cable wires for possible open circuits. If pulses are present at pin 11 of IC 11C, check for pulses at pin 10 of IC 11C. If pulses are missing at pin 10, check IC 11C by substitution. If pulses are present at pin 10, check Disk Controller IC (14H) by substitution.

DISK DRIVE MOTOR

Turn On the Computer with no diskette in Disk Drive A. Both Disk Drive Motors should be running. If one Disk Drive is not running, isolate the problem by checking for a Low Logic reading at pin 16 of Connector J2 and pin 1 of Connector J3 on the Disk Drive Board. If pin 16 of Connector J2 reads High the problem is on the System Board or the Connectors and Cables going to the System Board. If pin 16 of Connector J2 reads a Logic Low and pin 2 of Connector J3 reads a Logic High, the problem is on the Disk Drive Board. If pin 1 of Connector J3 reads a Logic Low the problem is on the Drive Motor Board or in Connector J3.

If pin 16 of Connector J2 reads Logic High, check the Logic reading at pin 8 of IC 7A on the System Board. If pin 8 reads a Logic Low, check pin 16 of Connectors CN6 and J2 for good connections and also check the cable for possible open wiring. If pin 8 of IC 7A reads a Logic High, check the Logic reading on pin 9 of IC 7A. If pin 9 reads a Logic High and pin 10 of IC 7A reads a Logic High, check IC 7A by substitution. If pin 9 of IC 7A reads Logic Low, check the Logic reading at pin 3 of IC 8B. If pin 3 reads a Logic Low, check IC 8B by substitution. If pin 3 reads Logic High, check for a pulse at pin 10 of IC 21E when the Reset Button (SW1) is pressed. If the Logic Pulse appears, check Counter IC (24C) by substitution. If no Logic appears, check IC21E by substitution.

If pin 16 of Connector J2 reads a Logic Low and pin 1 of Connector J3 reads a Logic High, check the logic reading at pin 7 of IC (IC3) on the Disk Drive Board. If pin 7 reads a Logic Low check resistance of Resistor Pack RA10 from pin 1 to pin 2 and also check Disk Drive Control IC (IC4) by substitution. If pin 7 of IC (IC3) reads a Logic High, check IC3 by substitution.

If pin 1 of Connector J3 reads a Logic Low, check the connections of Connector J3 for good connections. If the connections are good, turn Off the Computer and remove Connectors J1 and J2 from the Disk Drive. Remove 4 phillips screws holding the Disk Drive Board to the Disk Drive Chassis and remove the Disk Drive Board. Connect a 12V power supply to Connector P3 (ground to pin 3, 12V to pin 2). Connect a Silicon Diode from pin 1 to pin 3 of Connector P3 with the cathode connected to pin 3 to make the Drive Motor run continuously. Check the waveform at pin 5 of Motor Speed Controller IC (IC10). If the waveform is missing, check Electrolytics C32, C33, and C36, Capacitors C34 and C35, Diode ZD2, Resistors R77 and R78, Speed Control (VR2) and also check IC10 by substitution. If the waveform is present at pin 5 of IC10, check the waveform at the Collector of Switch Transistor (Q20). If the waveform is missing at Transistor Q20, check the voltages and components associated with Transistors Q33 and Q20. If the waveform is present at the collector of Transistor Q20, check the voltages and components associated with Transistors Q21 thru Q28 and also check the Drive Motor Coils for possible open windings.

If the Disk Drive Motor is not running at the correct speed, check the adjustment of the Speed Control (VR2), see the "Drive Motor Speed Adjustment" section of the Disk Drive Alignment procedures.

A timing circuit (ICs 21E, 13A and 24C) on the System Board is used to keep the Disk Drives running for one minute after the last Disk Drive access operation. If the Disk Drives will not stop running after one minute and pin 8 of Counter IC (24C) checks a Logic Low, check ICs 13A and 24C by substitution.

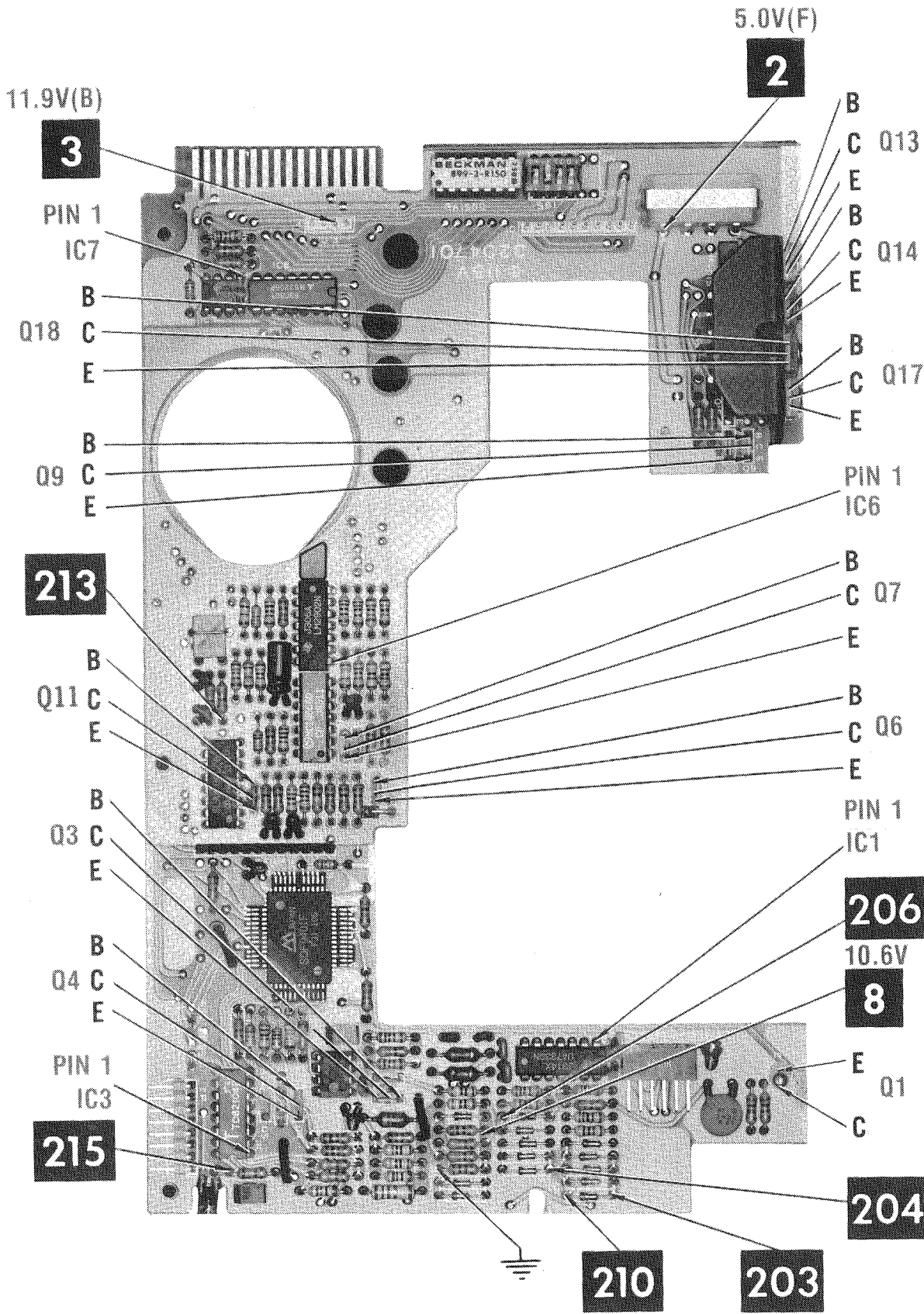

CSCS4-C

EPSON
MODEL QX-10

MAIN BOARD GridTrace LOCATION GUIDE

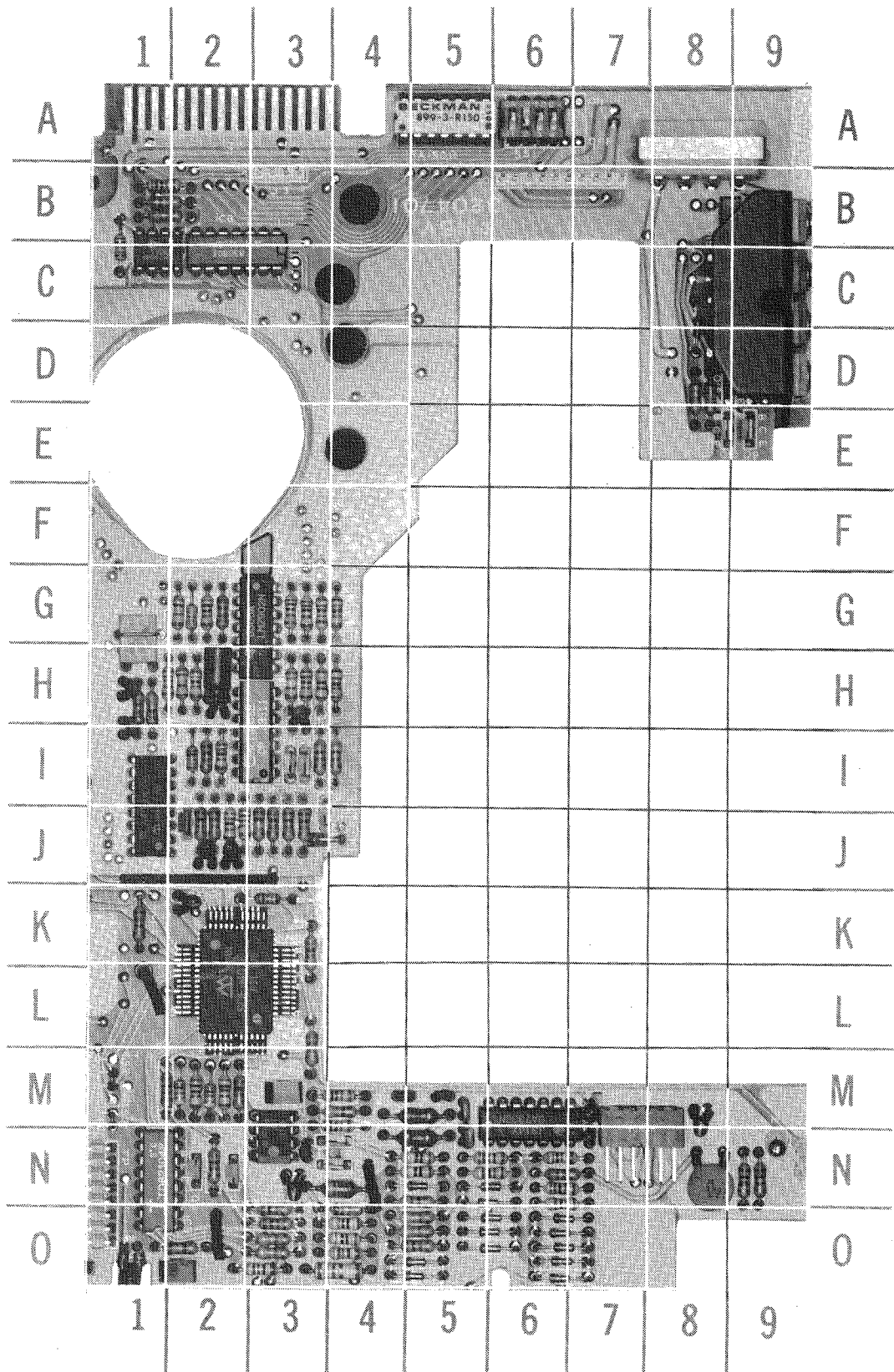

MAIN BOARD

A Howard W. Sams GRIDTRACE™ Photo

C1	N-8	Q15	D-9	R94	H-1
C2	M-7	Q16	D-9	RA10	J-2
C3	M-5	Q17	D-9	RA150	A-5
C4	M-5	Q18	C-9	SS1	A-6
C5	M-5	Q19	B-9	TP1	N-3
C6	M-4	R1	N-9	TP4	O-3
C7	N-3	R2	K-3	TP5	N-4
C8	M-3	R3	O-9	TP7	C-2
C9	O-2	R4	N-6	X	G-1
C10	M-3	R5	N-6	ZD1	N-5
C11	M-2	R6	N-6		
C12	M-2	R7	N-5		
C13	I-1	R8	N-6		
C14	H-1	R9	M-4		
C15	K-2	R10	M-4		
C16	K-3	R11	N-4		
C17	I-2	R12	O-4		
C18	J-2	R13	O-3		
C19	J-2	R14	O-4		
C20	H-2	R15	N-5		
C21	G-2	R16	O-4		
C22	C-1	R17	N-5		
C26	B-8	R18	O-5		
C27	B-9	R19	O-5		
C28	M-8	R20	N-6		
C29	M-7	R21	N-6		
C37	H-3	R22	O-3		
D1	O-6	R23	O-3		
D2	O-6	R24	O-3		
D3	O-6	R25	O-3		
D4	O-6	R26	O-5		
D5	O-6	R27	O-4		
D6	N-6	R28	O-4		
D7	M-6	R29	M-2		
D8	O-6	R30	N-2		
D9	O-6	R31	M-1		
D10	O-6	R32	M-2		
D11	O-5	R33	M-2		
D12	O-5	R34	M-3		
D14	C-3	R35	K-1		
IC1	M-6	R36	H-1		
IC2	N-3	R39	O-2		
IC3	N-1	R40	J-3		
IC4	L-2	R41	J-3		
IC5	J-1	R42	J-3		
IC6	G-3	R43	J-3		
IC7	C-1	R44	I-3		
IC8	C-2	R45	I-4		
IC9	I-3	R46	I-2		
J1	A-8	R47	J-2		
J2	A-2	R48	J-2		
J3	B-3	R49	J-2		
J4	B-6	R50	J-2		
J5	N-7	R51	H-4		
J6	N-9	R52	H-3		
L1	M-5	R53	H-3		
L2	N-5	R54	H-3		
L3	N-4	R55	G-4		
LED1	O-1	R56	G-3		
Q1	N-9	R57	G-3		
Q2	N-4	R58	G-3		
Q3	N-4	R59	H-1		
Q4	N-2	R60	H-2		
Q5	N-2	R61	H-2		
Q6	J-3	R62	I-2		
Q7	I-3	R63	G-2		
Q8	I-3	R64	G-2		
Q9	E-9	R65	G-2		
Q10	E-8	R66	B-1		
Q11	J-2	R67	B-1		
Q12	C-9	R68	B-1		
Q13	B-9	R69	D-8		
Q14	C-9	R70	D-8		

DRIVE MOTOR BOARD GridTrace LOCATION GUIDE

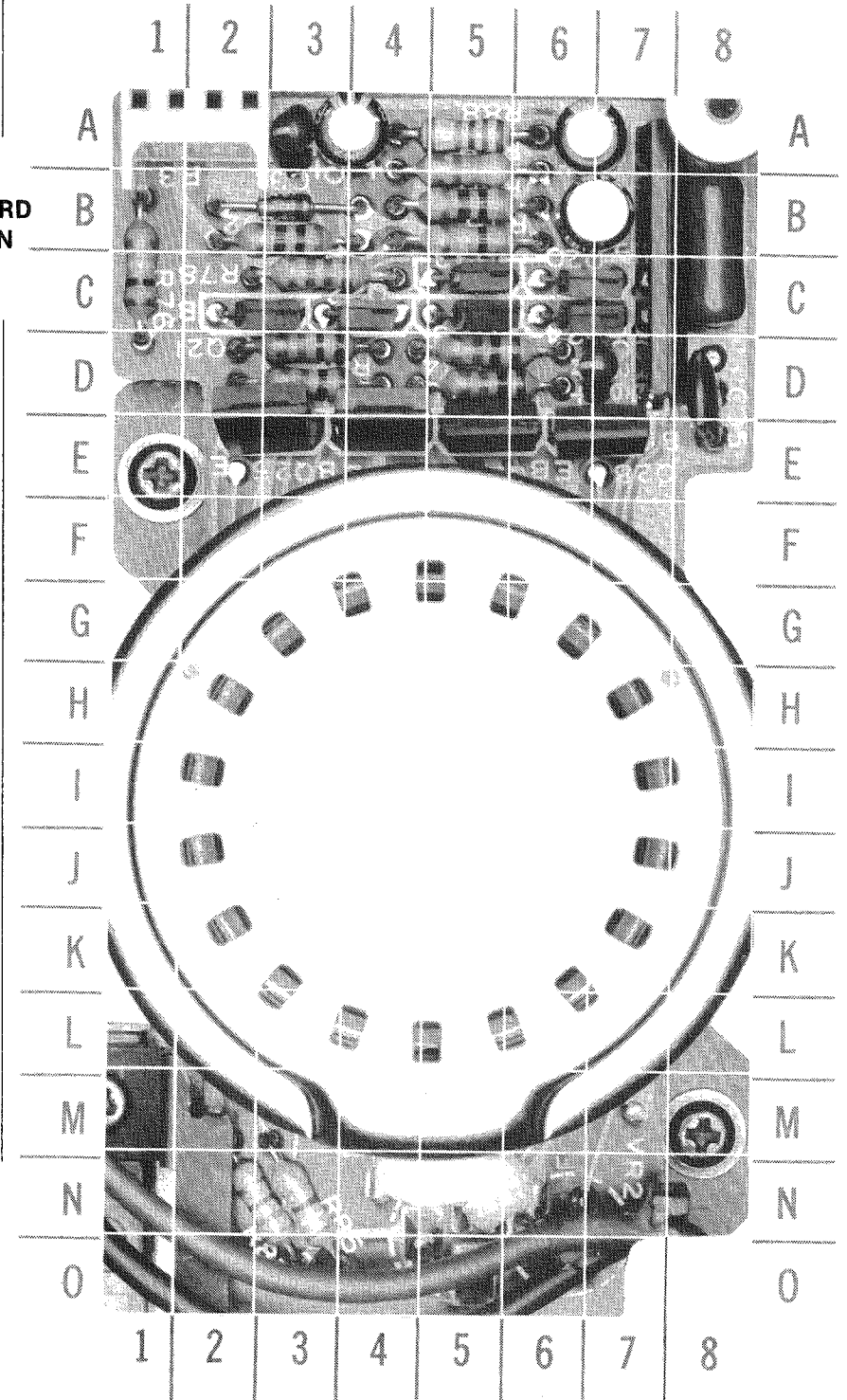

A Howard W. Sams GRIDTRACE™ Photo

DRIVE MOTOR BOARD

EPSON
MODEL QX-10

PARTS LIST AND DESCRIPTION

When ordering parts, state Model, Part Number, and Description

SEMICONDUCTORS (Select replacement transistor for best results)

ITEM No.	TYPE No.	MFG. PART No.	REPLACEMENT DATA						
			GENERAL ELECTRIC PART No.	NTE PART No.	PHILIPS ECG PART No.	RCA PART No.	WORKMAN PART No.	ZENITH PART No.	
DISK DRIVE									
D1 thru	MB555	X320010470							
D12	1S2095A	X320010460	GE-514	NTE519	ECG519	SK3100/519	WEP925/519	103-131	
D14	uA733CN	X440057350		NTE927D	ECG927D	SK7617/927D			
IC1	LM511N	X440223110		NTE922M	ECG922M	SK3668/922M		HE-442-75	
IC2	TD62104P	X440041040							
IC4	SDF9401F	X400244010		NTE987	ECG987	SK3643/987		HE-442-602	
IC5	SLA4030C0B	X400250300		NTE928M	ECG928M	SK3692/928M			
IC6	LM2902N	X440029020							
IC7	LM2904P	X440029040							
IC8	M53206P	X440032060	GE-7406	NTE7406	ECG7406	SK7406	WEP4066B/4066B	HE-443-698	
IC9	MCL14066B	X440160660		NTE4066B	ECG4066B	SK4066B		905-369	
IC10	CX085B	X440200650							
Q1	PT-350D	X350040090							
Q2, 3	2S02785	X302278594	GE-210	NTE85	ECG85	SK3124A/289A	WEP910/289	921-1114	
Q4, 5	2SA1150Y	X300115080	GE-269	NTE290A	ECG290A	SK3114A/290A	WEP911/290A	121-Z9003 *	
Q6	2S02785	X302278500	GE-210	NTE85	ECG85	SK3124A/289A	WEP910/289	921-1114	
Q7	2SA1175	X300117500	GE-269	NTE290A	ECG290A	SK3114A/290A	WEP911/290A	121-Z9003 *	
Q8	2S02785	X302278500	GE-210	NTE85	ECG85	SK3124A/289A	WEP910/289	921-1114	
Q9, 10	2S02785	X302278530	GE-210	NTE85	ECG85	SK3124A/289A	WEP910/289	921-1114	
Q11	2S02785	X302278500							
Q12	2SA1175	X300117593	GE-269	NTE290A	ECG290A	SK3114A/290A	WEP911/290A	121-Z9003 *	
Q13	2SA715C	X500071592		NTE374	ECG374	SK9042/374	WEP374/374	121-Z9105	
Q14	2SC1162C	X302116292	GE-57	NTE373	ECG373	SK9041/373	WEP880/184	121-Z9035	
Q15	2S02785	X302278593	GE-210	NTE85	ECG85	SK3124A/289A	WEP910/289	921-1114	
Q16	2SA1175	X300117593	GE-269	NTE290A	ECG290A	SK3114A/290A	WEP911/290A	121-Z9003 *	
Q17	2SA715C	X300071592		NTE374	ECG374	SK9042/374	WEP374/374	121-Z9105	
Q18	2SC1162C	X302116292	GE-57	NTE373	ECG373	SK9041/373	WEP880/184	121-Z9035	
Q19	2S02785	X302278593	GE-210	NTE85	ECG85	SK3124A/289A	WEP910/289	921-1114	
Q20	2S02785	X302278500	GE-210	NTE85	ECG85	SK3124A/289A	WEP910/289	921-1114	

CSCSA-C

EPSON
MODEL QX-10

PARTS LIST AND DESCRIPTION (Continued)

When ordering parts, state Model, Part Number, and Description

ELECTROLYTIC CAPACITORS

ITEM No.	RATING	MFGR. PART No.
C20	.47 50V 20% NP	X200584750

CAPACITORS

ITEM No.	RATING	MFGR. PART No.
C34	.01 100V 2%	X240211035

Items not listed are normally available at local distributors.

RESISTORS (Power and Special)

ITEM No.	RATING	REPLACEMENT DATA		
		MFGR. PART No.	NEW-TONE PART No.	WORKMAN PART No.
R4	8200 1% 1/4W Metal Film	X141428910		
R5	15K 1% 1/4W Metal Film	X141421520		
R8	15K 1% 1/4W Metal Film	X141421520		
R10	1000 1% 1/4W Metal Film	X141421010		
R11	1000 1% 1/4W Metal Film	X141421010		
R12	825 1% 1/4W Metal Film	X141428200		
R13	825 1% 1/4W Metal Film	X141428200		
R14	680 1% 1/4W Metal Film	X141426800		
R15	390 1% 1/4W Metal Film	X141423900		
R16	680 1% 1/4W Metal Film	X141426800		
R17	390 1% 1/4W Metal Film	X141423900		
R20	4700 1% 1/4W Metal Film	X141424710		
R21	4700 1% 1/4W Metal Film	X141424710		
R27	51.1 1% 1/2W Metal Film	X141220511		
R32	10K 1% 1/4W Metal Film	X141421020		
R33	20K 1% 1/4W Metal Film	X141422020		
R49	1000 1% 1/4W Metal Film	X141421010		
R50	1100 1% 1/4W Metal Film	X141421110		
R51	2200 1% 1/4W Metal Film	X141422210		
R52	3400 1% 1/4W Metal Film	X141423410		
R53	120K 1% 1/4W Metal Film	X141421230		
R54	16.9K 1% 1/4W Metal Film	X141421720		
R55	150K 1% 1/4W Metal Film	X141421530		
R56	150K 1% 1/4W Metal Film	X141421530		
R57	75K 1% 1/4W Metal Film	X141427520		
R58	75K 1% 1/4W Metal Film	X141427520		
R59	21.5K 1% 1/4W Metal Film	X141422220		
R60	324K 1% 1/4W Metal Film	X141423230		
R61	16K 1% 1/4W Metal Film	X141421620		
R62	20K 1% 1/4W Metal Film	X141422020		
R64	30K 1% 1/4W Metal Film	X141423020		
R65	60.4K 1% 1/4W Metal Film	X141426020		
R66	100K 1% 1/4W Metal Film	X141421030		
R88	255K 1% 1/4W Metal Film			
	280K 1% 1/4W Metal Film	X141422830		
R90	620 1% 1/8W Metal Film			
R91	20K 1% 1/8W Metal Film			
R92	20K 1% 1/8W Metal Film			
RA10	Resistor Network	X119461030(2)		
RA150	Resistor Network	X119471500(1)		

CSCS4-C
 EPSON
 MODEL QX-10

(1) Contains seven 150 5% 1/4W, Used in Drive A only.
 (2) Contains six 10K 5% 1/4W.

PARTS LIST AND DESCRIPTION (Continued)

When ordering parts, state Model, Part Number, and Description

CONTROLS (All wattages 1/2 watt, or less, unless listed)

ITEM NO.	FUNCTION	RESISTANCE	MFGR. PART NO.	NOTES
VR1	Balance	100		
VR2	Speed	50K		
VR3	Head Position	2000		
VR4	Head Position	50K		
VR5	Balance			
	Head Position	1000		
	Level			

COILS (RF-IF)

ITEM No.	FUNCTION	MFGR. PART No.
L1	RF Choke (330uH)	Y310219002
L2	RF Choke (330uH)	Y310219002

ITEM No.	FUNCTION	MFGR. PART No.
L3	RF Choke (680uH)	Y310219003

MISCELLANEOUS

ITEM No.	PART NAME	MFGR. PART No.	NOTES
HD1	Hall Effect Device		
HD2	Hall Effect Device		
LED 1	LED	X350200140	Activity, Red(+20V @ 12mA)
LED 2	LED		Part of Position 1 Sensor
LED 3	LED	GL350A	Part of Track Sensor
LED 4	LED	GL350A	Part of Write Protect Sensor
LED 5	LED	GL350A	Part of Index Sensor
M1	Motor/Generator		Drive
M2	Coil	Y310502131	Head Position, Assembly
M3	Head		W/R, E
SS1	Switch	Y310502157	Drive Select
X	Crystal	X504004400	445kHz
	Belt	Y310502112	Drive
	Motor	Y310502118	Drive, Complete Assembly
	P C Board	Y310502150	Main

CABINETS & CABINET PARTS (When ordering specify model, chassis & color)

ITEM	PART No.
Button, Push	Y310502147

ITEM	PART No.
Front Panel	Y310502117

MECHANICAL PARTS LIST

REF. NO.	PART NO.	DESCRIPTION
203	Y310502102	Eject Spring
204-	Y310502103	Eject Lock Lever
1		
205	Y310502107	Index Detector (B)
206-	Y310502108	Disk Drive Pulley
4		
207-	Y310502112	Drive Belt
4		

REF. NO.	PART NO.	DESCRIPTION
208	Y310502114	Disk Guide (B)
214	Y310502146	Disk Guide (L)
217	Y310502148	Write Protect Assembly
221-	Y310502142	Collet Lever Spring
7		
222	Y310502163	Collet Assembly
223	Y310502139	Index Detector (A)
225	Y310502145	Slide Lever Spring

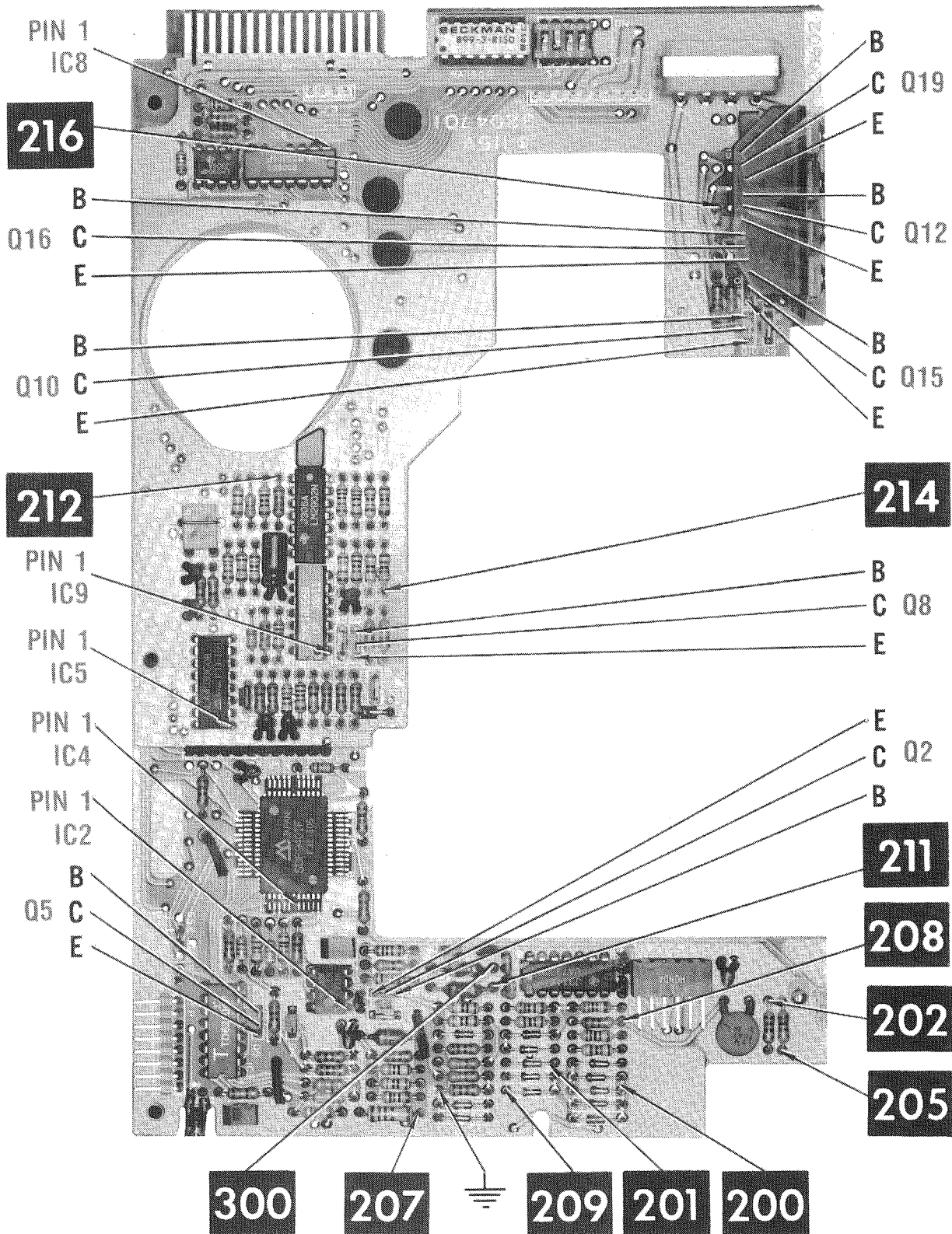

MAIN BOARD

LOGIC CHART

PIN NO.	IC IC1	IC IC2	IC IC3	PIN NO.	IC IC4	PIN NO.	IC IC4	PIN NO.	IC IC4	PIN NO.	IC IC4	PIN NO.	IC IC5	IC IC6	IC IC7	IC IC8	PIN NO.	IC IC10
1	(13)			1	L	17	L(8)	33	H	1	(13)	1	H	(13)	(13)	L(4)	1	(13)
2				2	P	18	L(3)	34	L	2		2	P	(13)		H(4)	2	
3				3	L	19	P	35	H	3		3	H	(13)		*	3	
4				4	P	20	P	36	(13)	4		4	L	H		L	4	
5				5	H	21		37	P	5		5	H(5)	(13)		P	5	
6				6	L	22	L(8)	38	(13)	6		6	H(11)	(13)		P	6	
7				7	H	23	H	39	P	7		7	H(5)	(13)		L	7	
8				8	L	24	P	40	P	8		8	H(6)	L(12)		H(9)	8	
9				9	*	25	H	41	P	9		9	L	(13)		L(8)		
10				10	L(10)	26	H(5)	42	P	10		10	P	(13)		P		
11				11	*	27	H(7)	43	P	11		11	*	L		P		
12				12	P	28	L	44	P	12		12	P	(13)		L(5)		
13				13	L(7)	29	L	45	(13)	13		13	H	(13)		H(5)		
14				14	H(6)	30	P	46	L	14		14	L	(13)		H		
15				15	H(5)	31	(13)			15		15	L					
16				16	P	32	H			16		16	H(5)					

Logic Probe Display

L = Low

H = High

P = Pulse

* = Open (No light On)

Logic probe readings taken while running the following program.

10 OPEN "0", #1, "B:SAMS"

20 FOR X = 1 TO 300

30 WRITE #1, "THIS IS A TEST"

40 NEXT X

50 CLOSE #1

60 GOTO 10

- (3) Probe indicates H if diskette is write protected.
 (4) Probe indicates P if diskette is write protected.
 (5) Probe indicates P when Head Position Motor is operating.
 (6) Probe indicates P when Head is moving out from center of diskette.
 (7) Probe indicates P when Head is moving in toward center of diskette.
 (8) Probe indicates H when Head is on track 00 and L when off track 00.
 (9) Probe indicates L when Head is on track 00 and H when off track 00.
 (10) Probe indicates H when drive motor is not running.
 (11) Probe indicates L when Head is moving in and H when Head is moving out from the center of the diskette.
 (12) Probe indicates H when Head is moving in and L when Head is moving out from the center of diskette.
 (13) Logic reading not taken.

MISCELLANEOUS ADJUSTMENTS

HEAD CLEANING

Use a non-abrasive cleaning diskette to clean the disk drive heads.

EQUIPMENT REQUIRED

A test program or a Disk Drive Tester is required which will turn On the Disk Drive and step the head to the track specified in the alignment procedures. Use a Dysan Analog Alignment Diskette 224/2A when an Alignment Diskette is specified in the alignment procedures. NOTE: This alignment diskette has only alignment patterns on it and does not contain any alignment programs.

VFO ADJUST

Connect input of scope to TP1 (collector of Q6) on System Board. Set the scope sweep time to $50\mu\text{Sec/cm}$, voltage range to 1V/cm and AC/DC input to DC input. While loading a program from the Disk Drive, adjust the VFO Adjust Control (VR2) on System Board for peak voltage on the waveform of 2.6V to 2.7V. See Figure 1.



Figure 1

2.6V TO 2.7V

0V
DC
Reference

SPINDLE SPEED ADJUSTMENT

Insert a blank diskette into the Disk Drive and close the door. Turn the Disk Drive on its side so the pattern on the flywheel is visible. Adjust the Speed Control (VR2) until the 60Hz pattern appears to stand still under a 60Hz fluorescent light. If 50Hz fluorescent lighting is used, use the 50Hz pattern on the pattern wheel.

If a Disk Drive Tester is being used, which provides a readout of the speed in rpm, adjust VR2 for a speed of $300\text{rpm} \pm 1.5\%$.

DRIVE MOTOR BALANCE ADJUSTMENT

Use the following procedure to prepare the Drive Motor Board for the Balance Adjustment:

Remove 4 screws holding the Disk Drive Board to the Disk Drive Chassis and remove the Disk Drive Board. Remove belt from drive motor. Remove two screws holding the Drive Motor Board and remove the Drive Motor and Board from the Disk Drive Chassis. Connect a 12V power supply to Connector P3 (negative to pin 3, positive to pin 2). To make the drive motor run continuously, connect a silicon diode from pin 1 to pin 3 of Plug P3 with the cathode connected to pin 3.

Connect channel A input of dual trace scope to TP10 (collector of transistor Q25) and channel B input to TP11 (collector of transistor Q28). Set the scope sweep time to 5mSec and voltage range of each channel to 50V. Adjust Balance Control (VR1) until both waveforms look identical. See Figure 2.

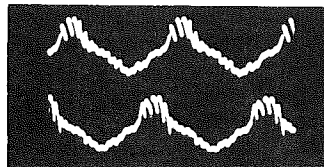

Figure 2

HEAD POSITION SENSOR ADJUSTMENT

Connect channel A input of scope to pin 9 of Connector P4 and the channel B input to pin 10 of Connector P4. Set the scope sweep time to 10mSec and voltage to 5V range. Set the Disk Drive to alternate between tracks 00 and 39. Adjust Head Position Balance Control (VR4) for waveforms of equal amplitude and adjust Head Position Level Control (VR5) for a peak to peak amplitude of 9V for each waveform. See Figure 2.

RADIAL HEAD ALIGNMENT

Connect channel A input of a dual trace scope to TP4 (pin 3 of IC2, channel B input to TP5 (pin 2 of IC2). Connect the external trigger input to TP7 (pin 5 of IC8) and connect the scope ground to TP1. Set the scope to add mode with channel B inverted, sweep time to 20mSec, AC input, trigger to positive slope and voltage to .2V range.

Insert the Alignment diskette, turn On the Disk Drive and set the head to track 16. Observe the cats-eye pattern, see Figure 5. The lobes should be within 70% of each other. If the lobes are out of tolerance, loosen the two screws holding the head position detector. Use a flat blade screwdriver placed in the slots on the chassis and head position detector to adjust lobes while they are within 70% of each other and retighten the retaining screws.

Move the head to track 39 and back to track 16, then to track 00 and back to track 16. See that the lobes are within tolerance when the head is on track 16.

EQUAL AMPLITUDE

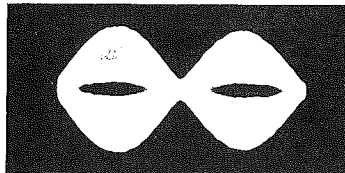

Figure 5

EPSON
MODEL QX-10

MISCELLANEOUS ADJUSTMENTS (Continued)

INDEX SENSOR ADJUSTMENT

Connect channel A input of a dual trace scope to TP4 (pin 3 of IC2), channel B input to TP5 (pin 2 of IC2), the external trigger input to TP7 (pin 5 of IC8) and the scope ground to TP1. Set the scope to add mode with channel B inverted, sweep time to $50\mu\text{Sec}$, AC input, trigger to positive slope and voltage to .2V range. Insert the Alignment Diskette in the Disk Drive and close the door. Turn On Disk Drive and set the head to track 01. Confirm that the leading edge of the burst occurs between $150\mu\text{Sec}$ to $500\mu\text{Sec}$ after the burst, see Figure 3. If the index sensor is out of adjustment, loosen the index sensor retaining screw on the top of the Disk Drive and use a flat blade screwdriver placed in the slots on the chassis and index sensor to adjust for $150\mu\text{Sec}$ to $500\mu\text{Sec}$, see "Chassis-Top View" photo.

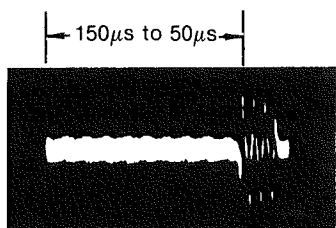

Figure 3

AZIMUTH ADJUSTMENT

Connect channel A input of a dual trace scope to TP4 (pin 3 of IC2), channel B input to TP5 (pin 2 of IC2), the external trigger input to TP7 (pin 5 of IC8) and connect the scope to TP1. Set the scope to add mode with channel B inverted, sweep time to .5mSec AC input, trigger to positive slope and voltage to .2V range.

Insert the Alignment Diskette, turn On the Disk Drive and set the head to track 34. Confirm that the pattern appears as shown in Figure 4. If the ratio of bursts 1 and 4 is less than .65 and the ratio of bursts 2 and 3 is less than .80, loosen the hex set screw (use 1.5mm hex wrench) located at the rear of the Disk Drive and adjust the Azimuth Eccentric Screw for the proper ratios. See the Disk Drive mechanical, Top View Photo. Optimum alignment is achieved when bursts 1 and 4 are equal in amplitude and bursts 2 and 3 are equal in amplitude.

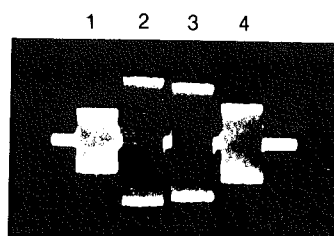

Figure 4

SCHEMATIC NOTES

- *— Circuitry not used in some versions
- Circuitry used in some versions
- See parts list
- ⊥ Ground
- ≡ Chassis
- ▽ Common tie point

Waveforms and voltages taken from ground, unless noted otherwise

Voltages, Waveforms and Logic probe readings taken while running the following program.

```
10 OPEN "0", #1, "B:SAMS"  
20 FOR X = 1 TO 300  
30 WRITE #1, "THIS IS A TEST"  
40 NEXT X  
50 CLOSE #1  
60 GOTO 10
```

Waveforms taken with triggered scope and Sweep/Time switch in Calibrate position, scope input set for DC coupling on 0 reference voltage waveforms. Switch to AC input to view waveforms after DC reference is measured when necessary. Each waveform is 7cm. width with DC reference voltage given at the bottom line of each waveform.

Time in μ sec. per cm, given with p-p reading at the end of each waveform.

Item numbers in rectangles appear in the alignment/adjustment instructions.

Supply voltages maintained as shown at input.

Voltages measured with digital meter, no signal.

Controls adjusted for normal operation.

Terminal identification may not be found on unit.

Capacitors are 50 volts or less, 5% unless noted.

Electrolytic capacitors are 50 volts or less, 20% unless noted.

Resistors are $\frac{1}{2}$ W or less, 5% unless noted.

Value in () used in some versions.

Measurements with switching as shown, unless noted.

- (3) Probe indicates H if diskette is write protected.
- (4) Probe indicates P if diskette is write protected.
- (5) Probe indicates P when Head Position Motor is operating.
- (6) Probe indicates P when Head is moving out from center of diskette.
- (7) Probe indicates P when Head is moving in toward center of diskette.
- (8) Probe indicates H when Head is on track 00 and L when off track 00.
- (9) Probe indicates L when Head is on track 00 and H when off track 00.
- (10) Probe indicates H when drive motor is not running.
- (11) Probe indicates L when Head is moving in and H when Head is moving out from the center of the diskette.
- (12) Probe indicates H when Head is moving in and L when Head is moving out from the center of diskette.
- (13) Logic reading not taken.

Logic Probe Display

L = Low

H = High

P = Pulse

* = Open (No light On)

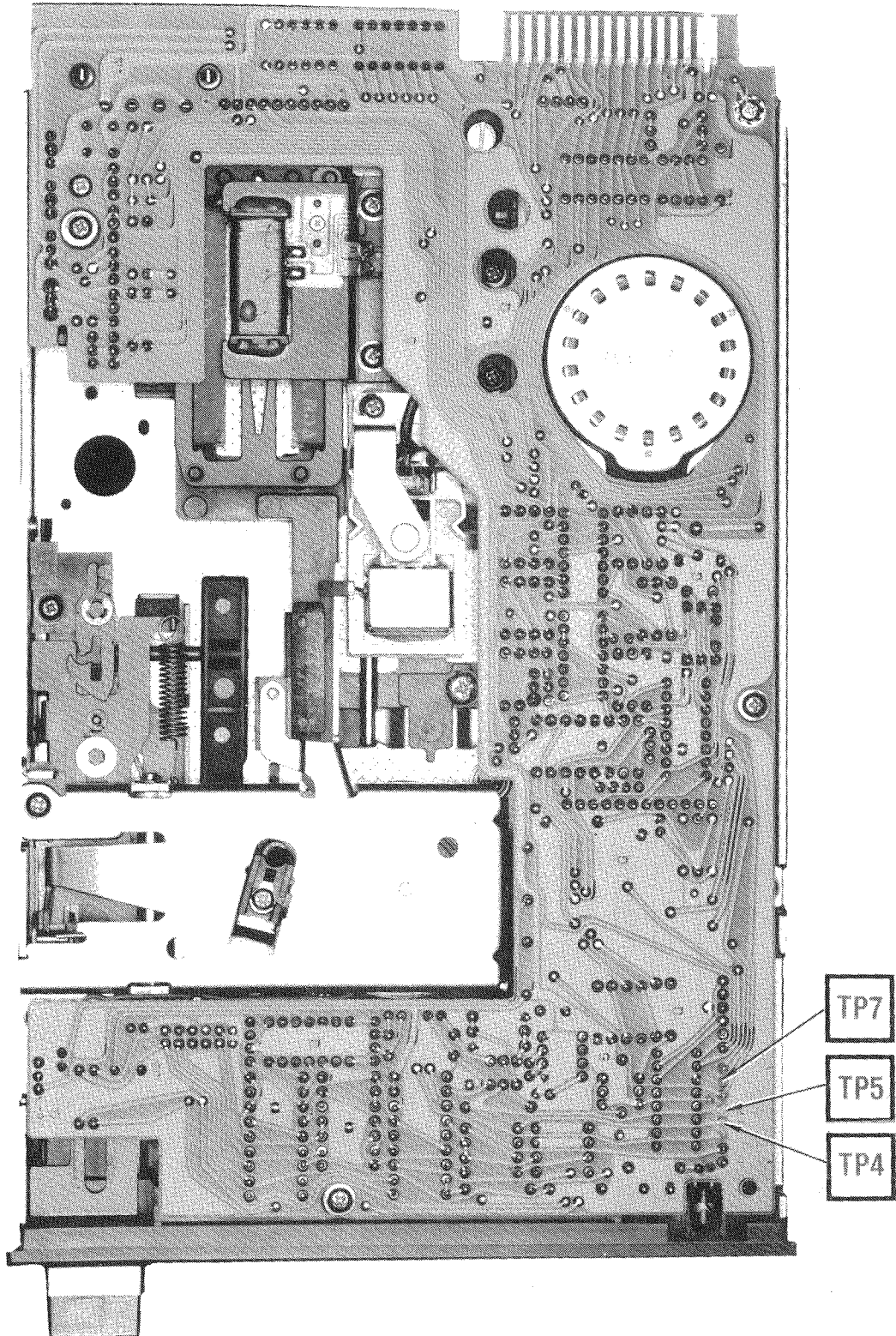

DISK DRIVE - TOP VIEW

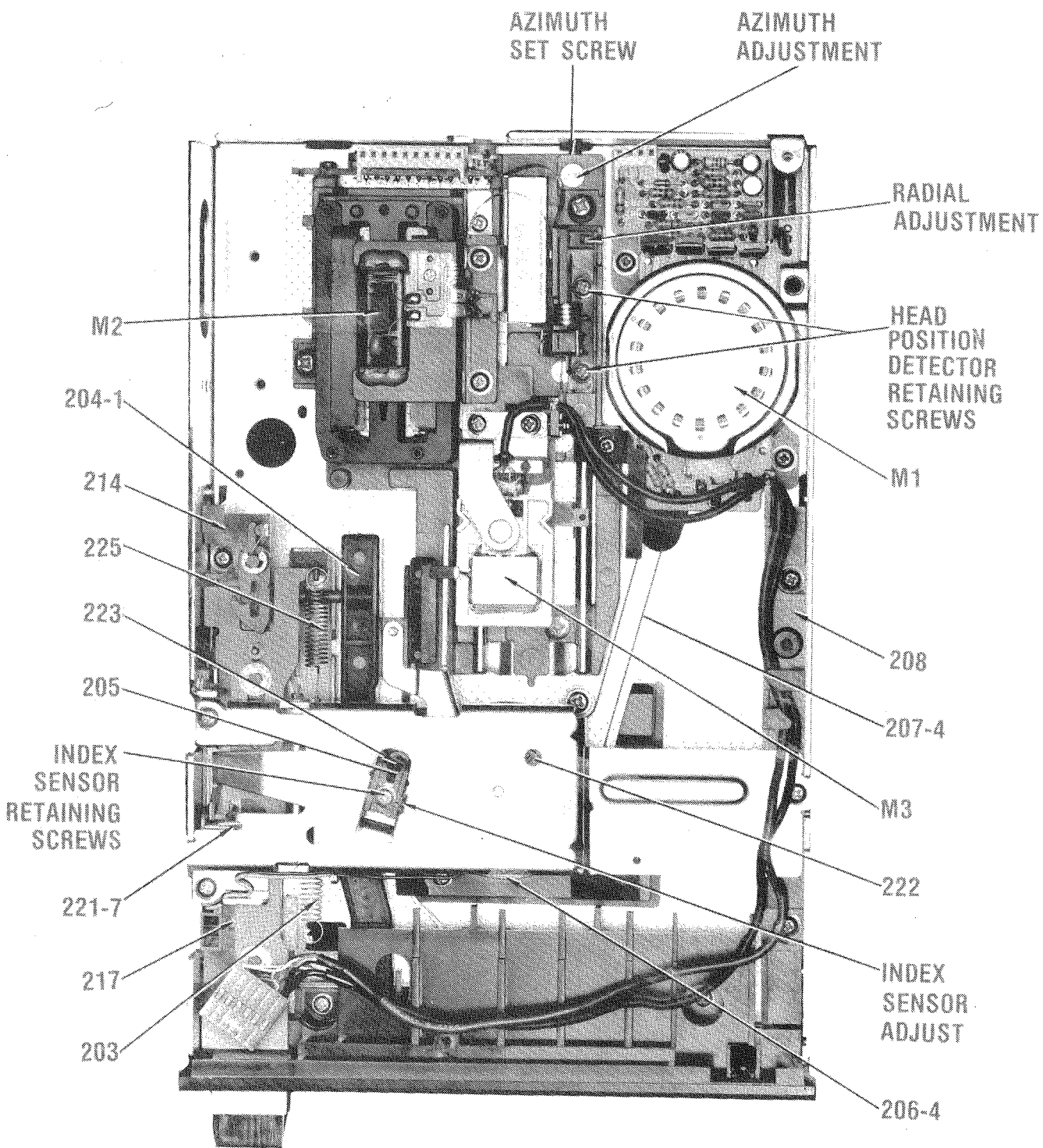

MECHANICAL - TOP VIEW